



**Prime Consulting Engineers Pty. Ltd.**

**Design Report:**

**3.5m Square Cantilever Umbrella**

**For**



Ref: R-22-174-2

Date: 20/01/2022

Amendment: -

Prepared by: KZ

Checked by: BG

---

**CONTENTS**

1	Introduction and Scope:	4
1.1	Project Description	4
1.2	References	4
1.3	Notation	4
2	Design Overview	5
2.1	Geometry Data	5
2.2	Assumptions & Limitations	6
2.3	Exclusions	6
2.4	Design Parameters and Inputs	6
2.4.1	Load Cases	6
2.4.2	Load Combinations	6
3	Specifications	7
3.1	Material Properties	7
3.2	Buckling Constants	7
3.3	Member Sizes & Section Properties	8
3.3.1	Rectangular Section	8
3.3.2	Circular Sections	8
4	Design Loads	9
5	Wind Analysis	9
5.1	Ultimate	9
5.2	Load Diagrams	12
5.2.1	Wind Load Ultimate ( $W_{U,min}$ )	12
5.2.2	Wind Load Ultimate ( $W_{U,max}$ )	12
6	Analysis	13
6.1	3D model	13
6.2	Results	14
6.2.1	Maximum deflection (serviceability)	14
6.2.2	Maximum Bending Moment	15
6.2.3	Maximum Shear	16
6.2.4	Maximum Axial Force	17
6.2.5	Maximum Reactions	17
7	Aluminium Design	18
8	Anchorage Design	18
8.1	Bolted Structure	18
8.2	Weighted structure	19
9	Summary and Recommendations	20
10	Appendix A – Detail Drawings	21
11	Appendix B – Section capacity	26
11.1	Checking Members Based on AS1664.1 ALUMINIUM LSD	26
11.1.1	Post	26



11.1.2	Cantilever Beam	30
11.1.3	Brace (typ.1)	34
11.1.4	Brace (typ.2)	39
11.1.5	Middle Beam	43
11.1.6	Corner Beam	47
11.1.7	Centre Pole	52
11.1.8	Summary Forces	56
12	Appendix 'C' – Anchorage Design	57

---

## 1 Introduction and Scope:

The report and certification are the sole property of Prime Consulting Engineers Pty. Ltd.

Prime Consulting Engineers have been engaged by Flare Shade Pty. Ltd. to carry out a structural analysis of three different sizes of Aluminium Cantilever Umbrellas for wind region A (non-cyclonic). It should be noted that the outcome of our analysis is limited to the selected items as outlined in this report.

This report shall be read in conjunction with the documents listed in the references (Section 1.2)

### 1.1 Project Description

The report examines the effect of 3s gust wind of (**refer to summary**) positioned for the worst effect on 3.5m square cantilever umbrella structure. The relevant Australian Standards AS1170.0:2002 General principles, AS1170.1:2002 Permanent, imposed and other actions and AS1170.2:2011 Wind actions are used. The design check is in accordance with AS1664.1 Aluminium Structures.

### 1.2 References

- The documents referred to in this report are as follows:
  - Report of results produced through SAP2000 V23 software & excel spreadsheets.
  - Detail drawing provided by manufacturer (YEEZE). Refer to appendix 'A'.
- The basic standards used in this report are as follows:
  - AS 1170.0:2002 – Structural Design Actions (Part 0: General principles)
  - AS 1170.1:2002 – Structural Design Actions (Part 1: Permanent, imposed, and other actions)
  - AS 1170.2:2011 – Structural Design Actions (Part 2: Wind Actions)
  - AS1664.1 Aluminium Structures.
- Section Properties of Aluminium Section provided by the client. (Refer Appendix 'A').
- The program(s) used for this analysis are as follows:
  - SAP2000 V23
  - Microsoft Excel

### 1.3 Notation

<i>AS/NZS</i>	Australian Standard/New Zealand Standard
<i>FEM/FEA</i>	Finite Element Method/Finite Element Analysis
<i>SLS</i>	Serviceability Limit State
<i>ULS</i>	Ultimate Limit State

## 2 Design Overview

### 2.1 Geometry Data

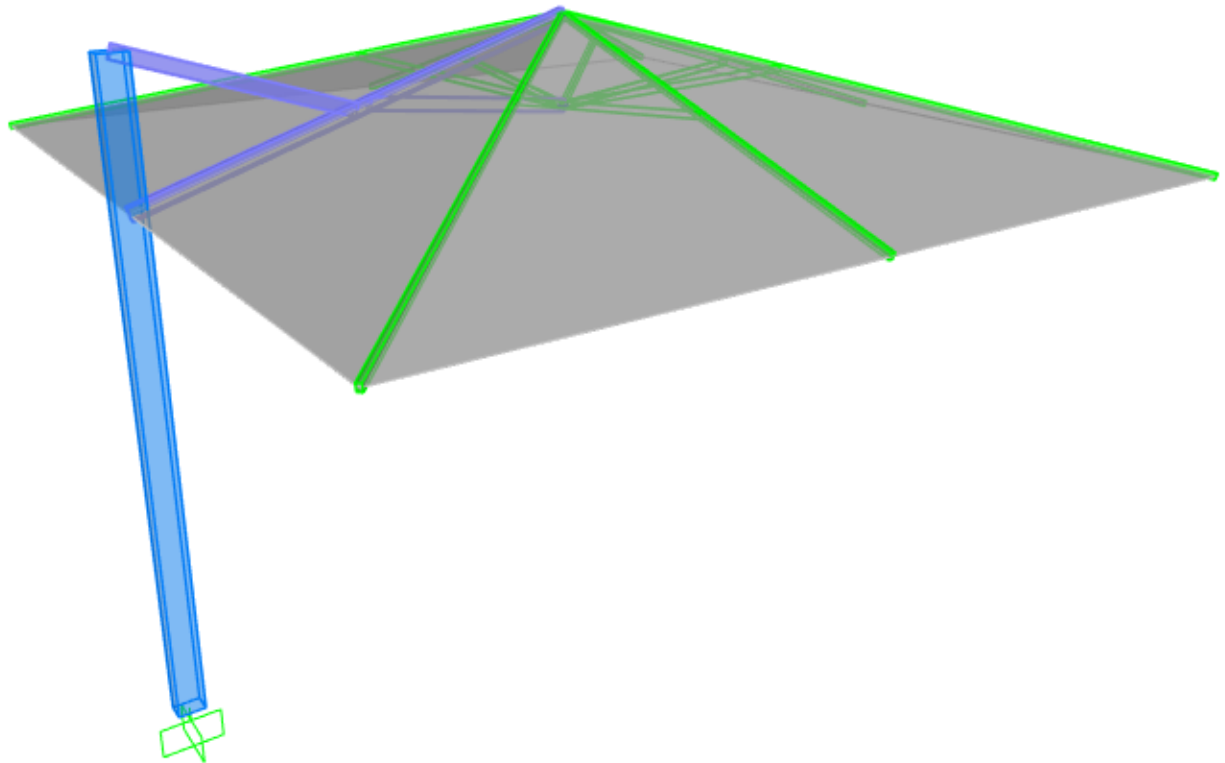
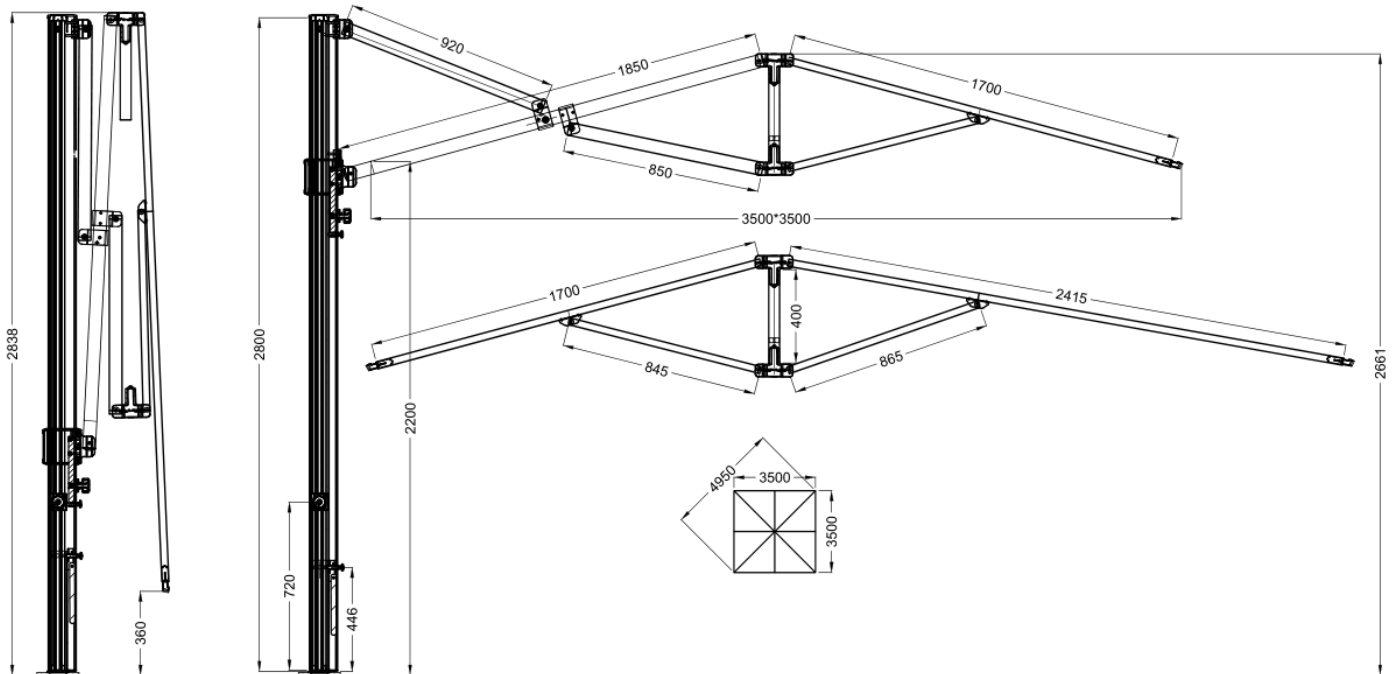

Isometric view of structures

---

## 2.2 Assumptions & Limitations

- The erected structure is for temporary use only.
- For forecast winds in excess of **(refer to summary)** the umbrella structure should be completely folded
- The structure may only be used in regions with wind classifications no greater than the limits specified in cl. 5 of this report.
- Parameters used for wind calculations:
  - TC 2
  - Wind Region A
- Topographical factors such as erecting the structure on the crest of a hill or on the top of an escarpment may result in a higher wind speed classification. Thus, special considerations should be taken to the topographical location of the installation site.
- Shall the site conditions/wind parameters exceed prescribed design wind actions (refer to cl.8), Prime Consulting Engineers Pty. Ltd. should be informed to determine appropriate wind classifications and amend computations accordingly.

## 2.3 Exclusions

- Design of fabric
- Wind actions due to tropical or severe tropical cyclonic areas.
- Super imposed loads such as live loads or snow and ice loads.

## 2.4 Design Parameters and Inputs

### 2.4.1 Load Cases

- |    |       |                                  |
|----|-------|----------------------------------|
| 1. | G     | Permanent actions (Dead load)    |
| 3. | $W_u$ | Ultimate wind action (ULS)       |
| 4. | $W_s$ | Serviceability wind action (SLS) |

### 2.4.2 Load Combinations

#### Strength (ULS):

- |    |            |                            |
|----|------------|----------------------------|
| 1. | 1.35G      | Permanent action only      |
| 3. | $0.9G+W_u$ | Permanent and wind actions |
| 4. | $1.2G+W_u$ | Permanent and wind actions |

#### Serviceability (SLS):

- |    |         |                      |
|----|---------|----------------------|
| 2. | $G+W_s$ | Wind service actions |
|----|---------|----------------------|

### 3 Specifications

#### 3.1 Material Properties

Material Properties										
6063-T5	$F_{tu}$	$F_{ty}$	$F_{cy}$	$F_{su}$	$F_{sy}$	$F_{bu}$	$F_{by}$	E	$k_t$	$k_c$
	152	110	110	90	62	317	179	70000	1	1.12

#### 3.2 Buckling Constants

TABLE 3.3(D) BUCKLING CONSTANTS					
Type of member and stress	Intercept, MPa		Slope, MPa		Intersection
Compression in columns and beam flanges	$B_c$	119.26	$D_c$	0.49	$C_c$ 99.33
Compression in flat plates	$B_p$	134.29	$D_p$	0.59	$C_p$ 93.61
Compression in round tubes under axial end load	$B_t$	132.00	$D_t$	3.62	$C_t$ *
Compressive bending stress in rectangular bars	$B_{br}$	194.52	$D_{br}$	1.26	$C_{br}$ 103.26
Compressive bending stress in round tubes	$B_{tb}$	183.09	$D_{tb}$	9.34	$C_{tb}$ 79.80
Shear stress in flat plates	$B_s$	75.86	$D_s$	0.25	$C_s$ 124.54
Ultimate strength of flat plates in compression	$k_1$	0.35	$k_2$	2.27	
Ultimate strength of flat plates in bending	$k_1$	0.5	$k_2$	2.04	

\*  $C_t$  shall be determined using a plot of curves of limit state stress based on elastic and inelastic buckling or by trial and error solution

### 3.3 Member Sizes & Section Properties

#### 3.3.1 Rectangular Section

MEMBER(S)	Section	b	d	t	y <sub>c</sub>	A <sub>g</sub>	Z <sub>x</sub>	Z <sub>y</sub>	S <sub>x</sub>	S <sub>y</sub>	I <sub>x</sub>	I <sub>y</sub>	J	r <sub>x</sub>	r <sub>y</sub>
		mm	mm	mm	mm	mm <sup>2</sup>	mm <sup>3</sup>	mm <sup>3</sup>	mm <sup>3</sup>	mm <sup>3</sup>	mm <sup>4</sup>	mm <sup>4</sup>	mm <sup>4</sup>	mm	mm
Post	120x85x3	85	120	3	60.0	1194.0	41441.7	34291.3	49329.0	38881.5	2486502.0	1457379.5	2775221.2	45.6	34.9
Cantilever Beam	60x35x3.5	35	60	3.5	30.0	616.0	9420.7	6709.7	11837.0	7987.0	282620.3	117420.3	251961.0	21.4	13.8
Brace 1	60x35x3.5	35	60	3.5	30.0	616.0	9420.7	6709.7	11837.0	7987.0	282620.3	117420.3	251961.0	21.4	13.8
Brace 2	30x20x1.5	20	30	1.5	15.0	141.0	1141.1	894.6	1401.8	1049.3	17115.8	8945.8	17744.2	11.0	8.0
Middle Beam	30x20x1.5	20	30	1.5	15.0	141.0	1141.1	894.6	1401.8	1049.3	17115.8	8945.8	17744.2	11.0	8.0
Corner Beam	30x20x1.5	20	30	1.5	15.0	141.0	1141.1	894.6	1401.8	1049.3	17115.8	8945.8	17744.2	11.0	8.0
Brace	100x50x5	50	100	5	50.0	1400.0	34733.3	22466.7	44000.0	26500.0	1736666.7	561666.7	1305401.8	35.2	20.0

#### 3.3.2 Circular Sections

MEMBER(S)	Section	d	t	y <sub>c</sub>	A <sub>g</sub>	Z <sub>x</sub>	Z <sub>y</sub>	S <sub>x</sub>	S <sub>y</sub>	I <sub>x</sub>	I <sub>y</sub>	J	r <sub>x</sub>	r <sub>y</sub>
		mm	mm	mm	mm <sup>2</sup>	mm <sup>3</sup>	mm <sup>3</sup>	mm <sup>3</sup>	mm <sup>3</sup>	mm <sup>4</sup>	mm <sup>4</sup>	mm <sup>4</sup>	mm	mm
Centre Pole	48x1.8	48	1.8	24.0	261.3	2908.7	2908.7	3843.9	3843.9	69809.9	69809.9	139619.8	16.3	16.3



## 4 Design Loads

Self weight	G	self weight
3s 55km/hr gust	$W_u$	0.116 $C_{fig}$ (kPa)
3s 20km/hr gust	$W_s$	0.015 $C_{fig}$ (kPa)

## 5 Wind Analysis

### 5.1 Ultimate



**Project:** 4m square Cantilever Umbrella

**Job no.** 22-174-2

**Designer:** KZ

**Date:** 17/01/2022

**Amendment:** -

Name	Symbol	Value	Unit	Notes	Ref.
<b>Input</b>					
Importance level		2			Table 3.1 - Table 3.2 (AS1170.0)
Annual probability of exceedance		Temporary			Table 3.3
Regional gust wind speed		55.008	Km/hr		
Regional gust wind speed	$V_R$	15.28	m/s		
Wind Direction Multipliers	$M_d$	1			Table 3.2 (AS1170.2)
Terrain Category	TC	2			
Terrain Category Multiplier	$M_{z,Cat}$	0.91			
Shield Multiplier	$M_s$	1			4.3 (AS1170.2)
Topographic Multiplier	$M_t$	1			4.4 (AS1170.2)
Site Wind Speed	$V_{Site,\beta}$	13.90	m/s	$V_{Site,\beta} = V_R * M_d * M_{z,Cat} * M_s * M_t$	
Pitch	$\alpha$	15	Deg		
Pitch	$\alpha$	-	rad		



Width	B	4	m		
Length	D	4	m		
Height	Z	2.5	m		
Porosity Ratio	$\delta$	1		ratio of solid area to total area	
<b>Wind Pressure</b>					
$\rho_{air}$	$\rho$	1.2	Kg/m <sup>3</sup>		
dynamic response factor	$C_{dyn}$	1			
Wind Pressure	$\rho * C_{fig}$	<b>0.116</b>	Kg/m <sup>2</sup>	$\rho = 0.5 \rho_{air} * (V_{des, \beta})^2 * C_{fig} * C_{dyn}$	2.4 (AS1170.2)
<b>WIND DIRECTION 1 (<math>\theta=0</math>)</b>					
<b>External Pressure</b>					
<b>1. Free Roof</b>				$\alpha = 0^\circ$	D7
Area Reduction Factor	$K_a$	1			
local pressure factor	$K_l$	1			
porous cladding reduction factor	$K_p$	1.00			
External Pressure Coefficient <b>MIN</b>	$C_{P,w}$	-0.3			
External Pressure Coefficient <b>MAX</b>	$C_{P,w}$	0.4			
External Pressure Coefficient <b>MIN</b>	$C_{P,l}$	-0.4			
External Pressure Coefficient <b>MAX</b>	$C_{P,l}$	0			
aerodynamic shape factor <b>MIN</b>	$C_{fig,w}$	-0.30			
aerodynamic shape factor <b>MAX</b>	$C_{fig,w}$	0.40			
aerodynamic shape factor <b>MIN</b>	$C_{fig,l}$	-0.40			
aerodynamic shape factor <b>MAX</b>	$C_{fig,l}$	0.00			
Pressure Windward <b>MIN</b>	P	<b>-0.03</b>	<b>kPa</b>		
Pressure Windward <b>MAX</b>	P	<b>0.05</b>	<b>kPa</b>		
Pressure Leeward <b>MIN</b>	P	<b>-0.05</b>	<b>kPa</b>		
Pressure Leeward <b>MAX</b>	P	<b>0.00</b>	<b>kPa</b>		
<b>WIND DIRECTION 2 (<math>\theta=90</math>)</b>					
<b>External Pressure</b>					
<b>4. Free Roof</b>				$\alpha = 180^\circ$	D7



Area Reduction Factor	$K_a$	1		
local pressure factor	$K_l$	1		
porous cladding reduction factor	$K_p$	1.00		
External Pressure Coefficient <b>MIN</b>	$C_{P,w}$	-0.3		
External Pressure Coefficient <b>MAX</b>	$C_{P,w}$	0.4		
External Pressure Coefficient <b>MIN</b>	$C_{P,l}$	-0.4		
External Pressure Coefficient <b>MAX</b>	$C_{P,l}$	0		
aerodynamic shape factor <b>MIN</b>	$C_{fig,w}$	-0.30		
aerodynamic shape factor <b>MAX</b>	$C_{fig,w}$	0.40		
aerodynamic shape factor <b>MIN</b>	$C_{fig,l}$	-0.40		
aerodynamic shape factor <b>MAX</b>	$C_{fig,l}$	0.00		
Pressure <b>MIN (Windward Side)</b>	P	-0.03	kPa	
Pressure <b>MAX (Windward Side)</b>	P	0.05	kPa	
Pressure <b>MIN (Leeward Side)</b>	P	-0.05	kPa	
Pressure <b>MAX (Leeward Side)</b>	P	0.00	kPa	

<b>WIND EXTERNAL PRESSURE</b>	<b>Direction1</b>		<b>Direction2</b>	
	<b>Min (Kpa)</b>	<b>Max (Kpa)</b>	<b>Min (Kpa)</b>	<b>Max (Kpa)</b>
<b>Windward</b>	-0.035	0.046	-0.035	0.046
<b>Leeward</b>	-0.046	0.000	-0.046	0.000

## 5.2 Load Diagrams

### 5.2.1 Wind Load Ultimate ( $W_{U,min}$ )

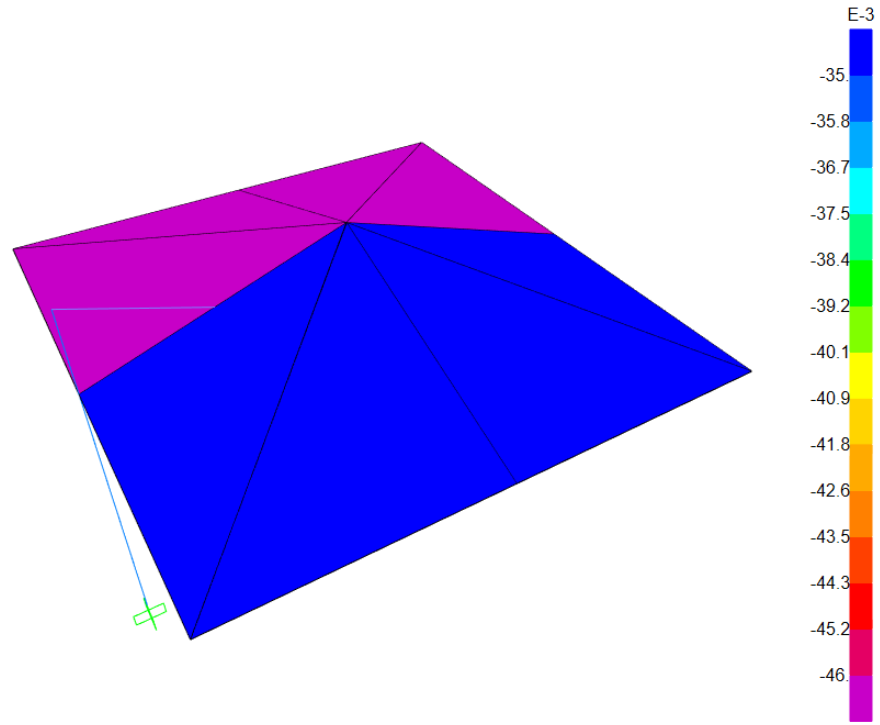

### 5.2.2 Wind Load Ultimate ( $W_{U,max}$ )

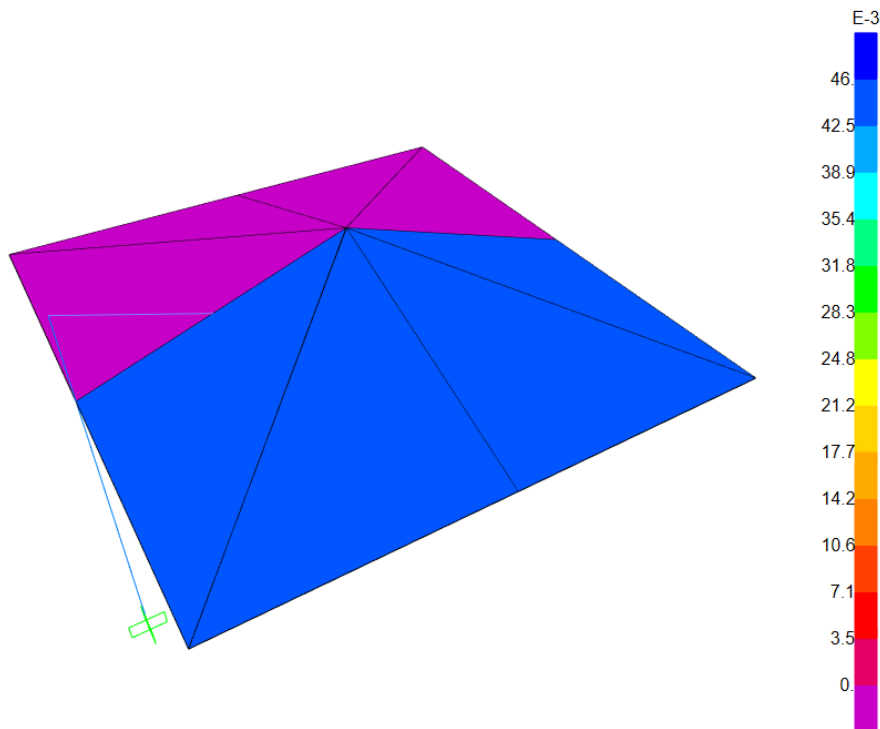

## 6 Analysis

### 6.1 3D model

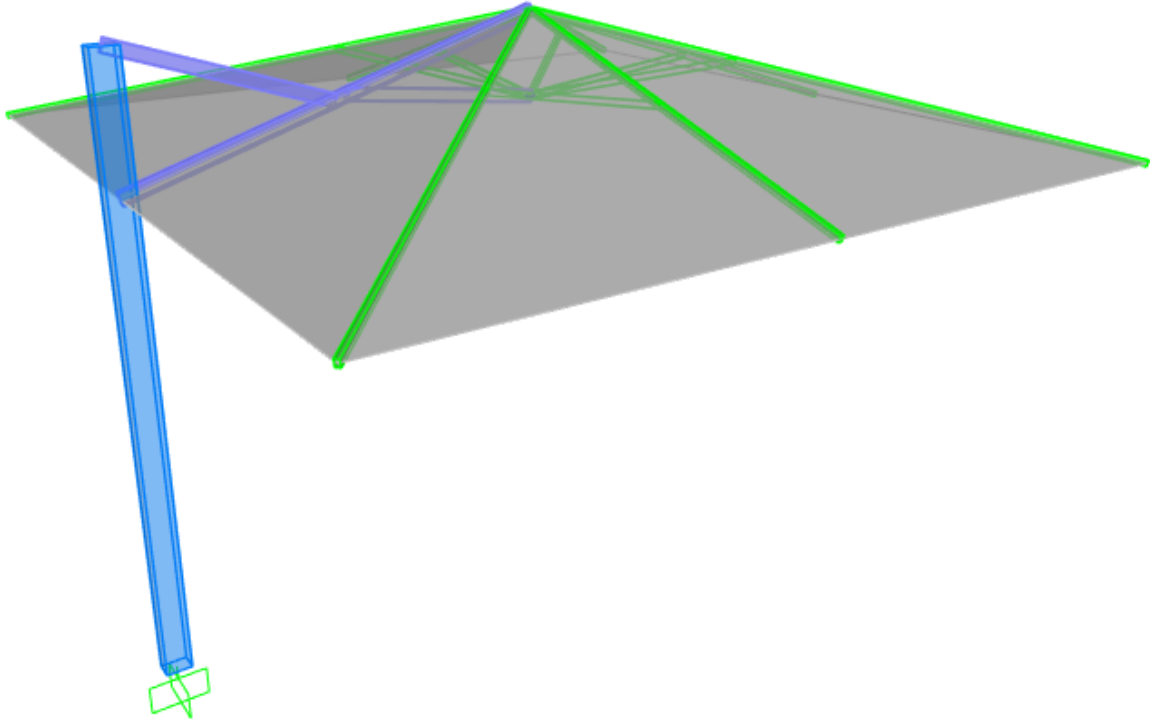

## 6.2 Results

### 6.2.1 Maximum deflection (serviceability)

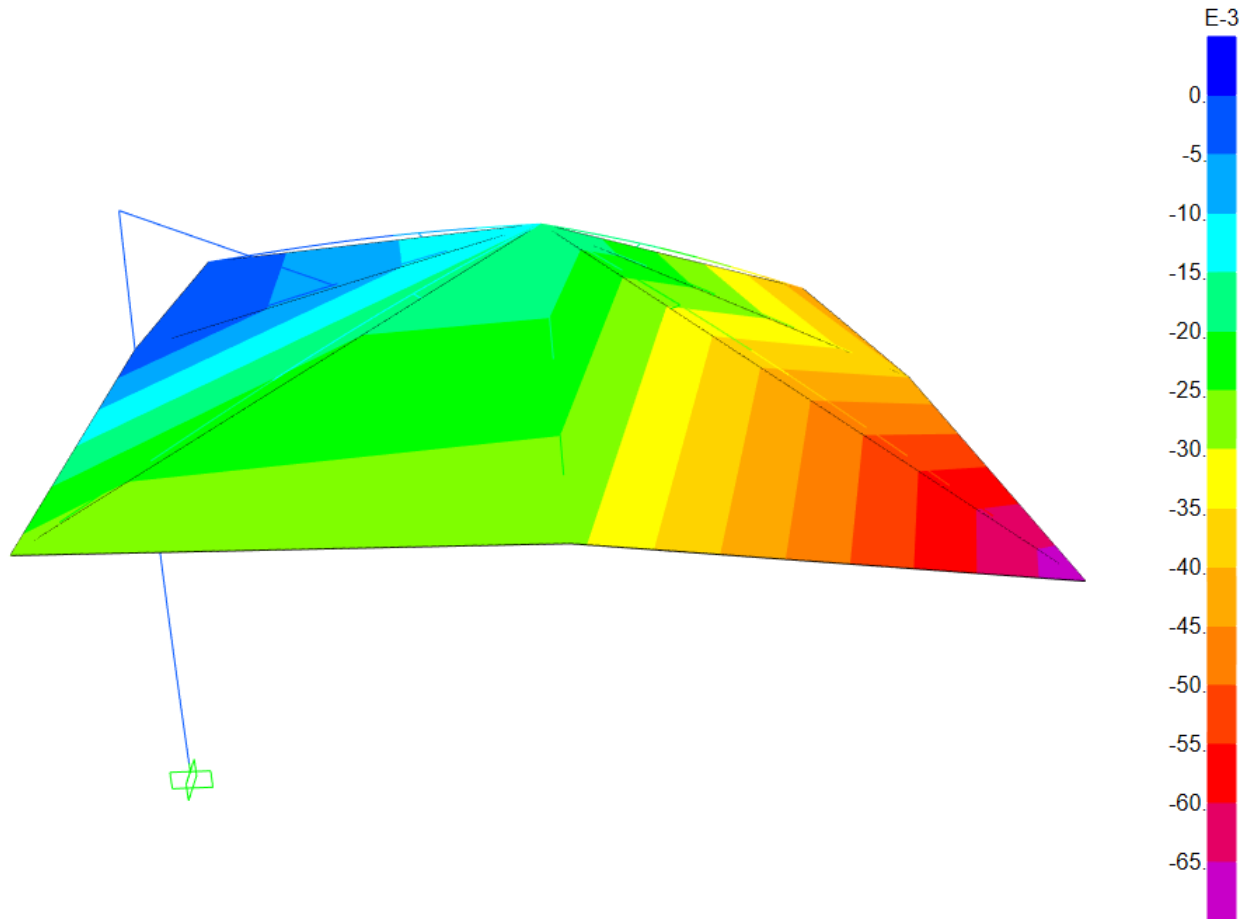

---

## 6.2.2 Maximum Bending Moment

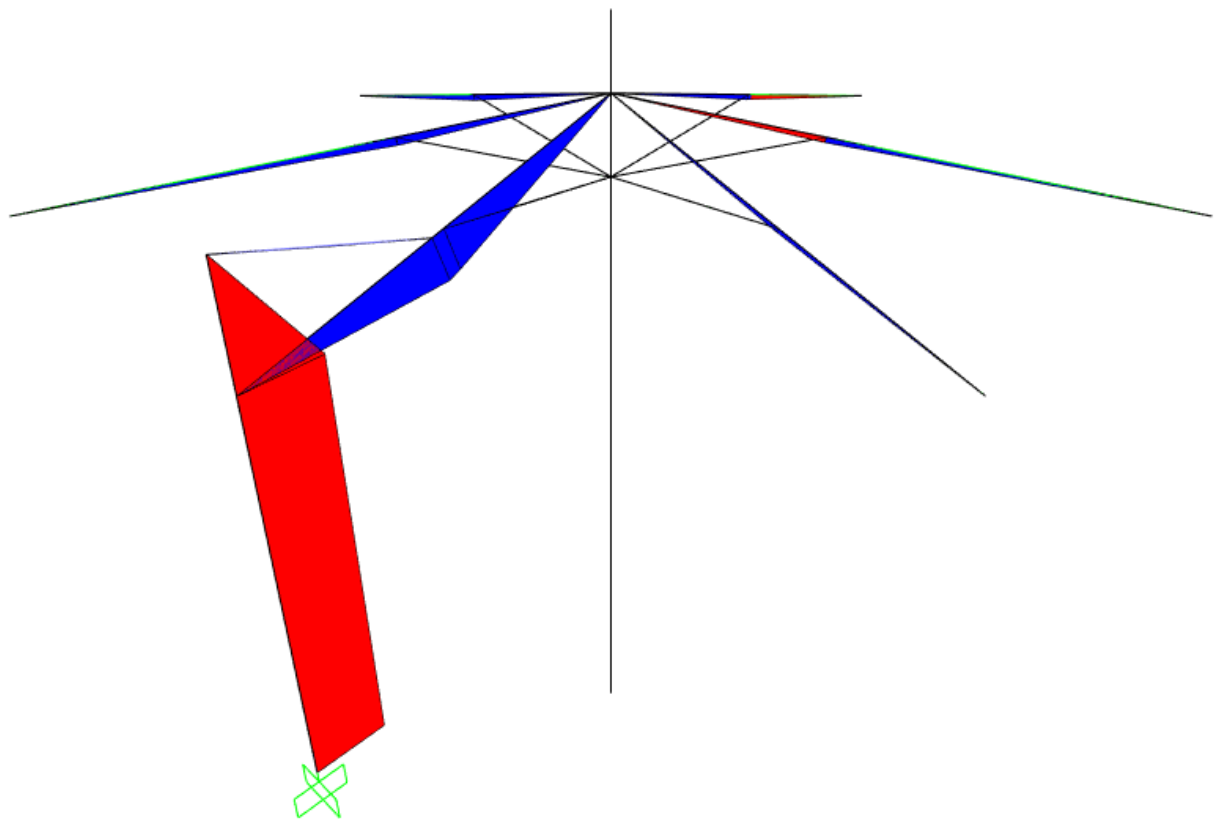

### 6.2.3 Maximum Shear

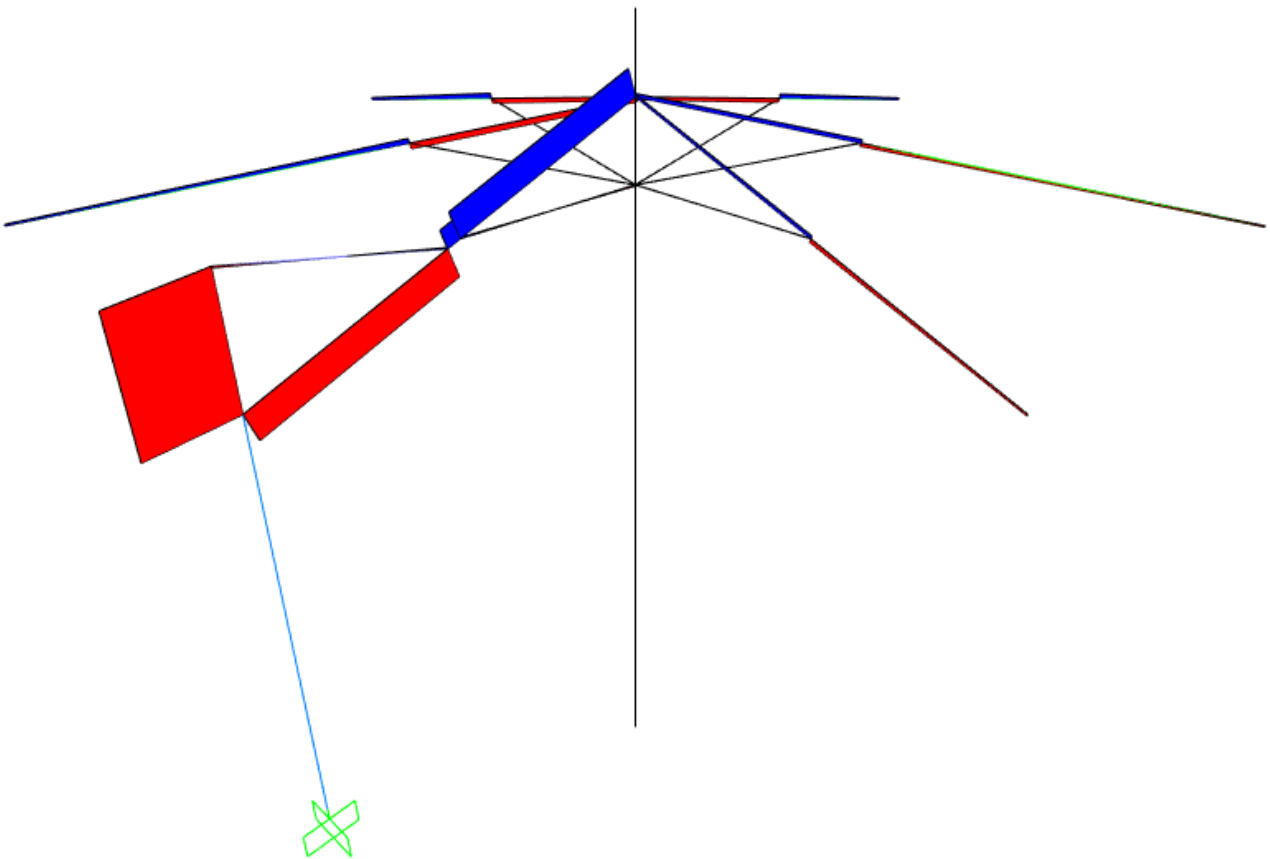



### 6.2.4 Maximum Axial Force

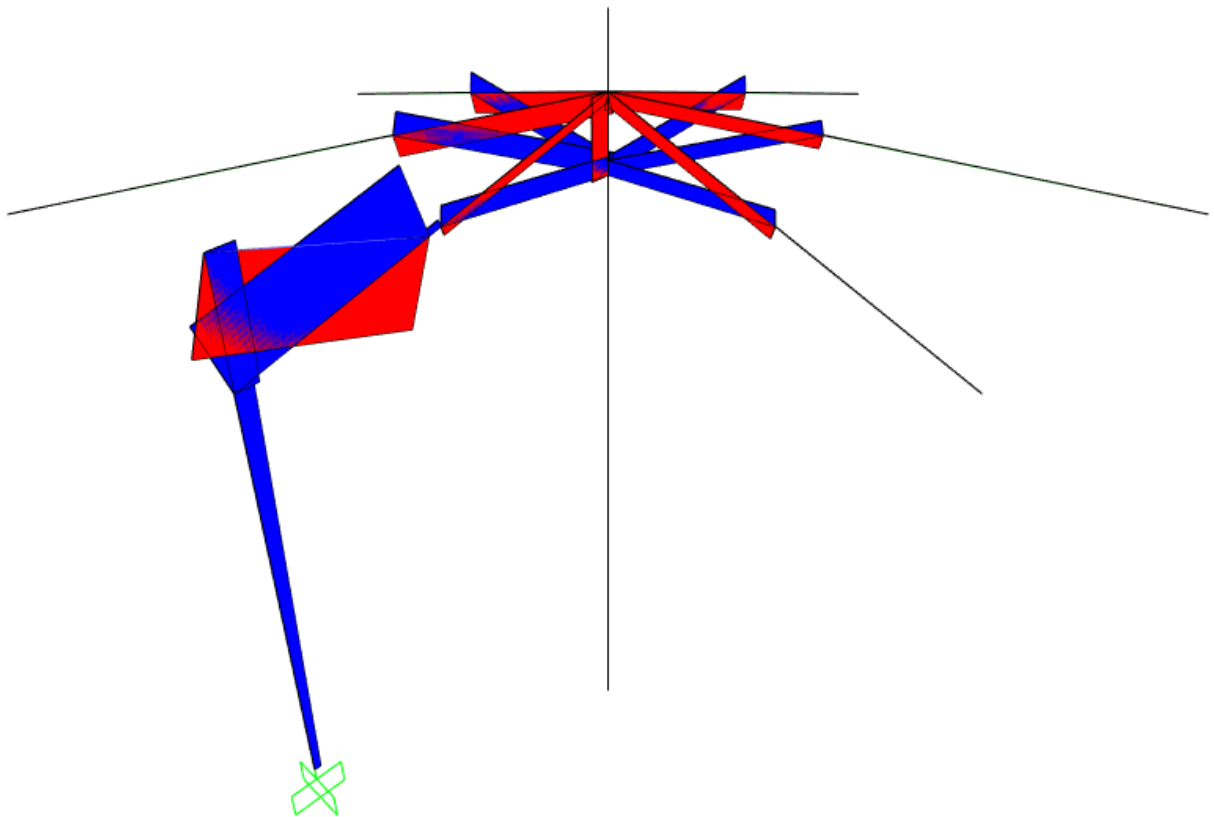

### 6.2.5 Maximum Reactions

TABLE: Joint Reactions						
OutputCase	F1 KN	F2 KN	F3 KN	M1 KN-m	M2 KN-m	M3 KN-m
1.2G+Wmax	1.964E-12	-0.048	0.608	-0.1317	-0.8242	-0.0845
0.9G+Wmin	-1.55E-12	-0.012	-0.251	-0.0315	0.6199	-0.0202

## 7 Aluminium Design

All members pass for the defined design wind actions. Refer to Appendix 'B' for section capacities and factor of safeties.

## 8 Anchorage Design

### 8.1 Bolted Structure

Refer to Appendix 'C' for details.

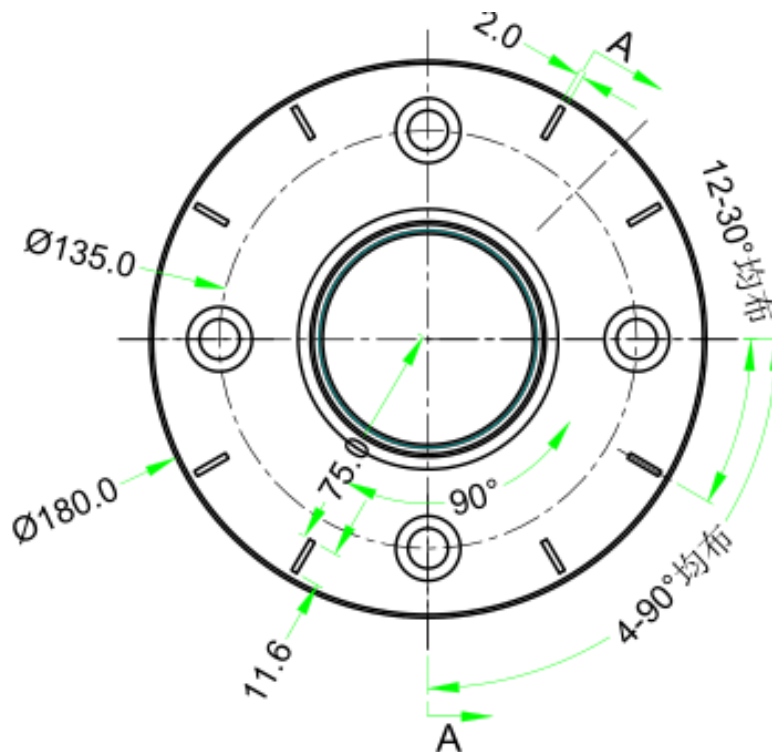

Base Plate Radius: 90mm  
 Edge distance: 25mm  
 Assumed Concrete Slab Thickness: 180mm  
 Maximum Tensile Force on bolts: 5.33kN  
 Design of supporting concrete slab is by others.

**Use 4/HLA-Z1 M10 bolt by All Fasteners**

## 8.2 Weighted structure



Base Plate Holder: 850mm x 850mm x 70mm

Design forces:

$M^* = 0.62 \text{ kN.m}$

$P = 0.25 \text{ kN}$

$0.73 \times 0.85 + 0.251 \times 0.85/2 = W/2 \times 0.85 \rightarrow W = 1.71 \text{ kN}$

**180kg ballast is required to be distributed evenly on the 850 x 850 x 70 base plate holder**

## 9 Summary and Recommendations

- The 3.5m Square Cantilever Umbrella Structure as specified is capable of withstanding 3s gust wind speed up to **55km/hr**.
- The umbrella structure is required to be folded for forecast winds in excess of **20km/hr** to avoid any potential permanent deformation/buckling due to excessive deflection as a result of higher wind speeds.
- The anchorage system described in **Cl. 8** (180kg ballast or 4/HLA-Z1 M10 bolt) is required to resist against uplift & overturning forces due to design wind loads.

Yours faithfully,

Prime Consulting Engineers Pty. Ltd.

Kevin Zia, BEng, Meng, MIEAust, CPENG NER



Tubes and connectors

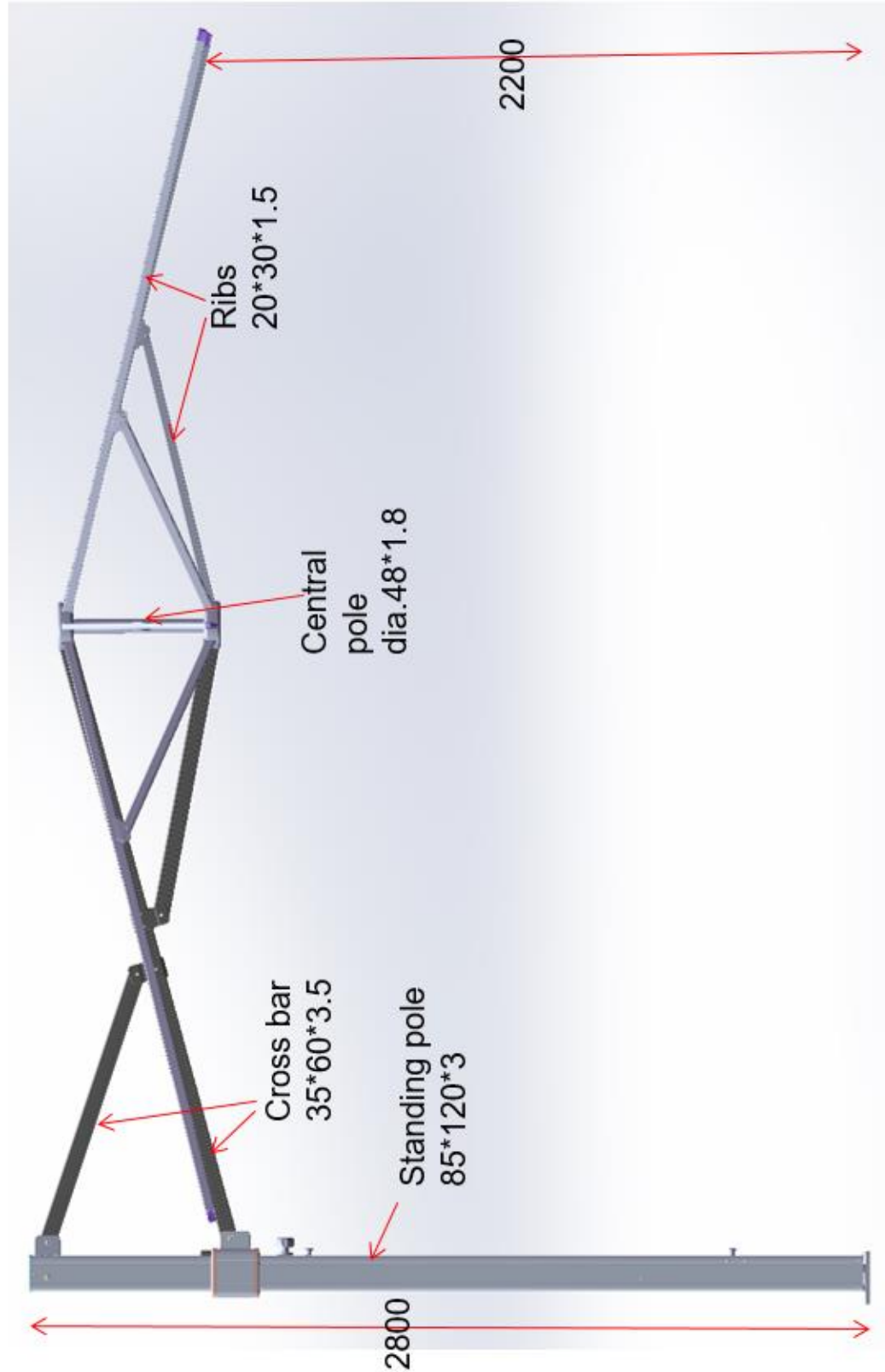

未注线性尺寸公差表

0.5-3mm	±0.1	>3-6mm	±0.2	>6-30mm	±0.3	>30-120mm	±0.5	>120-400mm	±0.5
---------	------	--------	------	---------	------	-----------	------	------------	------

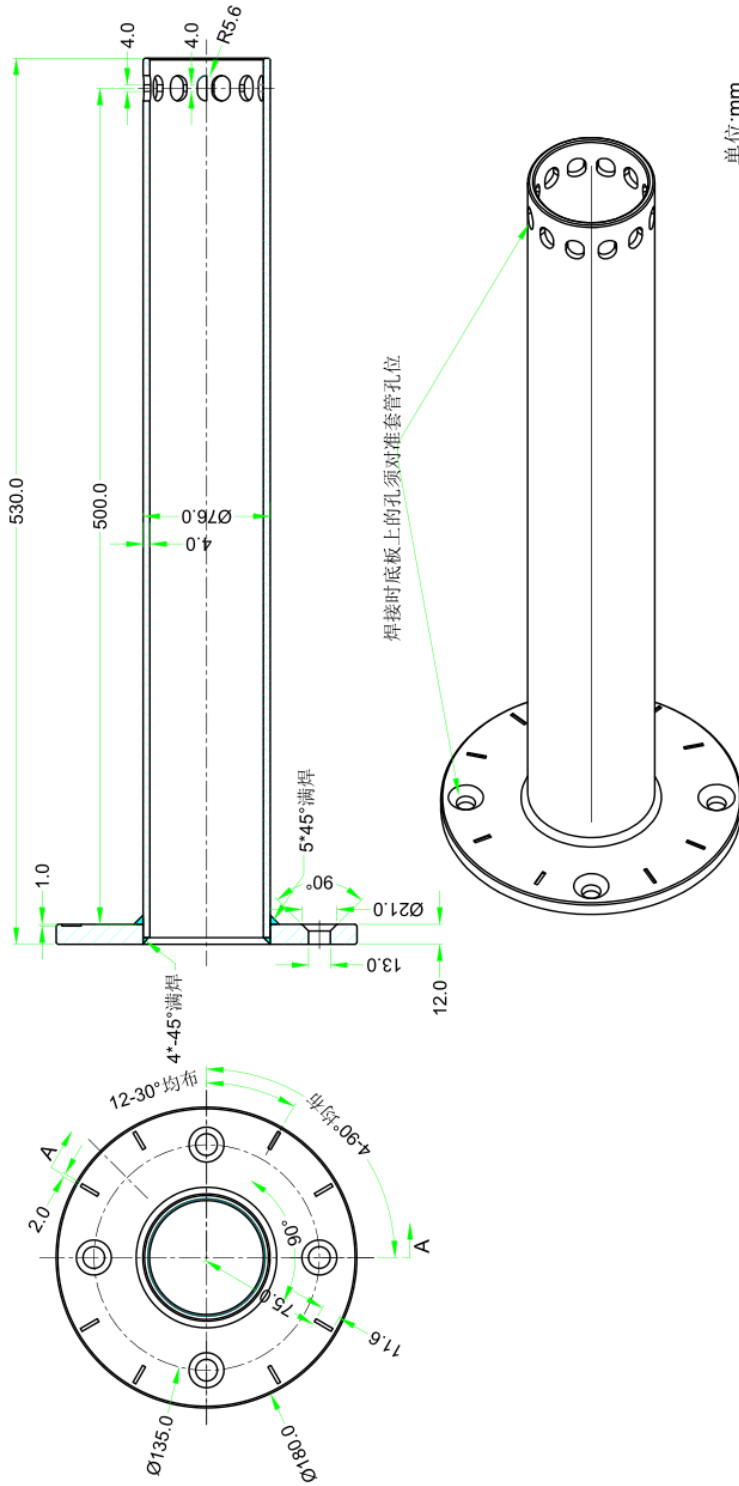

单位:mm

修改版次	修改内容	修改人	日期	名称	底座焊件	宁波亿泽日用品有限公司
				图号	T-01-014	YEEZE
				材质		制图
				单重	g	校对
				比例	1:4	批准
				版次	A	

技术要求:

- 1、产品表面无锋边、未注倒角C0.5;
- 2、焊接时焊缝要求平滑,不得有气孔夹渣等焊接缺陷;
- 3、产品表面镀锌处理。

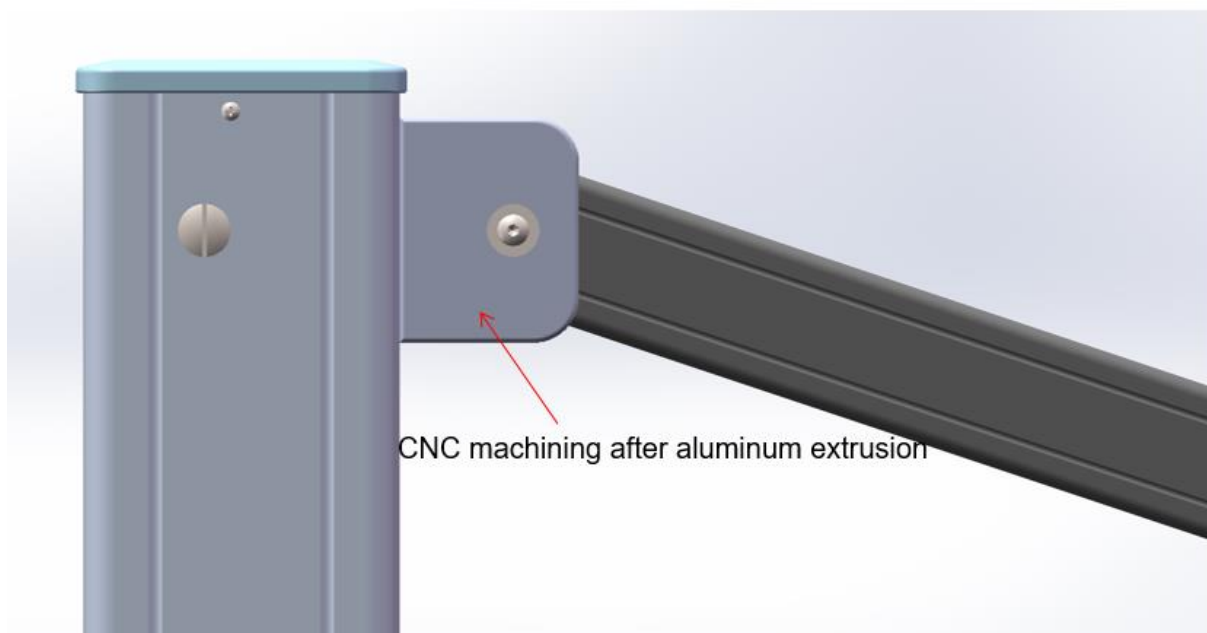
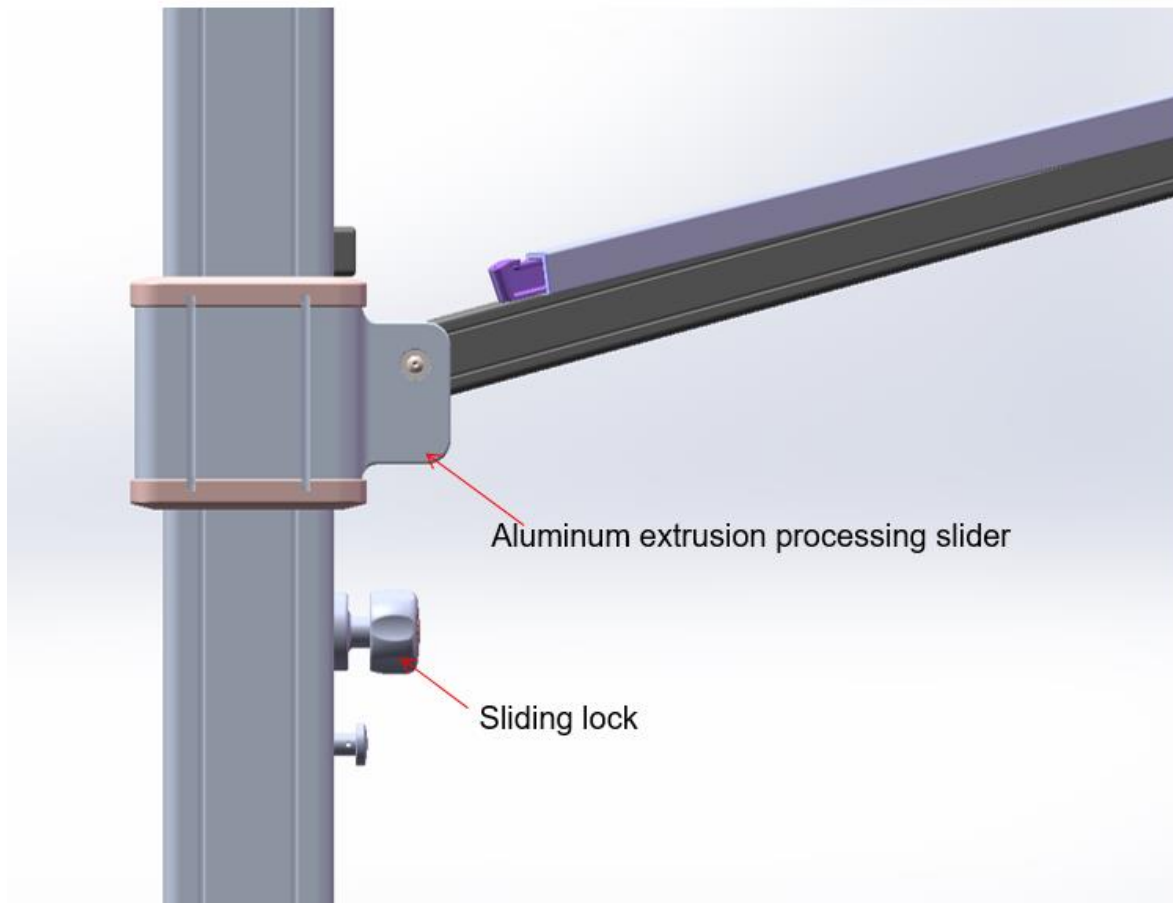



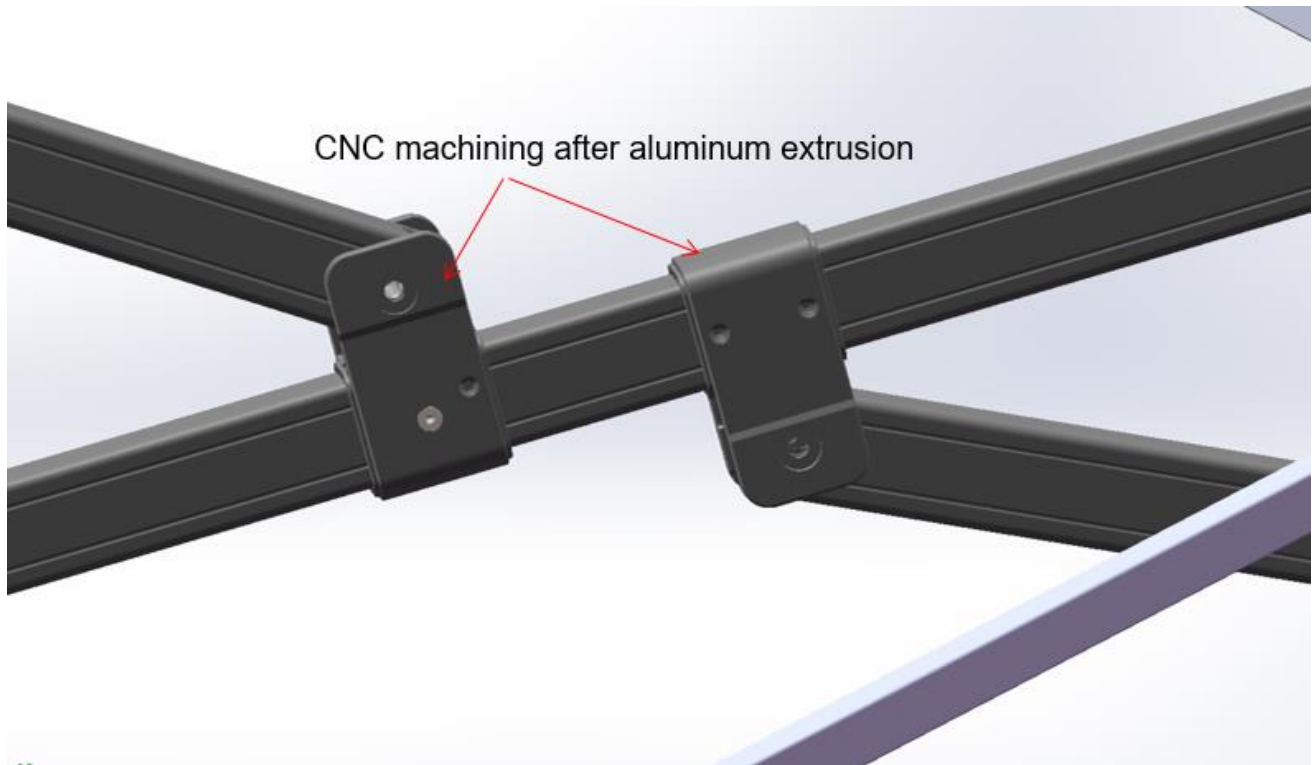

## 11 Appendix B – Section capacity

### 11.1 Checking Members Based on AS1664.1 ALUMINIUM LSD

#### 11.1.1 Post



Job no.

21-174-2

Date:

17/01/2022

NAME	SYMBOL	VALUE	UNIT	NOTES	REF
<b>120x85x3</b>	<b>Post</b>				
Alloy and temper	6063-T5				AS1664.1
Tension	$F_{tu}$	= 152	MPa	<i>Ultimate</i>	T3.3(A)
	$F_{ty}$	= 110	MPa	<i>Yield</i>	
Compression	$F_{cy}$	= 110	MPa		
	$F_{su}$	= 90	MPa	<i>Ultimate</i>	
Shear	$F_{sy}$	= 62	MPa	<i>Yield</i>	
	$F_{bu}$	= 317	MPa	<i>Ultimate</i>	
Bearing	$F_{by}$	= 179	MPa	<i>Yield</i>	
Modulus of elasticity	$E$	= 70000	MPa	<i>Compressive</i>	T3.4(B)
	$k_t$	= 1			
	$k_c$	= 1			
<b>FEM ANALYSIS RESULTS</b>					
Axial force	$P$	= 0.524	kN	<i>compression</i>	
	$P$	= 0	kN	<i>Tension</i>	
In plane moment	$M_x$	= 0.8242	kNm		
Out of plane moment	$M_y$	= 0.2379	kNm		
<b>DESIGN STRESSES</b>					
Gross cross section area	$A_g$	= 1194	mm <sup>2</sup>		
In-plane elastic section modulus	$Z_x$	= 41441.7	mm <sup>3</sup>		
Out-of-plane elastic section mod.	$Z_y$	= 34291.282	mm <sup>3</sup>		
Stress from axial force	$f_a$	= $P/A_g$			<i>compression</i>
		= 0.44	MPa		

Stress from in-plane bending	$f_{bx}$	=	<b>0.00</b>	<b>MPa</b>	Tension	
		=	$M_x/Z_x$			
		=	<b>19.89</b>	<b>MPa</b>	compression	
Stress from out-of-plane bending	$f_{by}$	=	$M_y/Z_y$			
		=	<b>6.94</b>	<b>MPa</b>	compression	
<i>Tension</i>						
<b>3.4.3 Tension in rectangular tubes</b>						
	$\phi F_L$	=	<b>104.50</b>	<b>MPa</b>		
		OR				
	$\phi F_L$	=	<b>129.20</b>	<b>MPa</b>		
<b>COMPRESSION</b>						
<b>3.4.8 Compression in columns, axial, gross section</b>						
<b>1. General</b>						
						... 3.4.8.1
Unsupported length of member	L	=	2800	mm		
Effective length factor	k	=	1.00			
Radius of gyration about buckling axis (Y)	$r_y$	=	34.94	mm		
Radius of gyration about buckling axis (X)	$r_x$	=	45.63	mm		
Slenderness ratio	$kLb/r_y$	=	62.97			
Slenderness ratio	$kL/r_x$	=	61.36			
Slenderness parameter	$\lambda$	=	0.795			
	$D_c^*$	=	39.0			
	$S_1^*$	=	0.24			
	$S_2^*$	=	1.25			
	$\phi_{cc}$	=	0.833			
Factored limit state stress	$\phi F_L$	=	<b>73.54</b>	<b>MPa</b>		
<b>2. Sections not subject to torsional or torsional-flexural buckling</b>						
						... 3.4.8.2
Largest slenderness ratio for flexural buckling	$kL/r$	=	62.97			
<b>3.4.10 Uniform compression in components of columns, gross section - flat plates</b>						
<b>1. Uniform compression in components of columns, gross section - flat plates with both edges supported</b>						
						...
	$k_1$	=	0.35			3.4.10.1
						T3.3(D)
Max. distance between toes of fillets of supporting elements for plate	$b'$	=	79			
	t	=	3	mm		
Slenderness	$b/t$	=	26.333333			

Limit 1	$S_1$	=	12.06		
Limit 2	$S_2$	=	49.94		
Factored limit state stress	$\phi F_L$	=	<b>93.08</b>	<b>MPa</b>	
Most adverse compressive limit state stress	$F_a$	=	73.54	MPa	
Most adverse tensile limit state stress	$F_a$	=	104.50	MPa	
Most adverse compressive & Tensile capacity factor	$f_a/F_a$	=	0.01		PASS
<b>BENDING - IN-PLANE</b>					
<b>3.4.15</b> <i>Compression in beams, extreme fibre, gross section rectangular tubes, box sections</i>					
Unbraced length for bending	$L_b$	=	2200	mm	
Second moment of area (weak axis)	$I_y$	=	1.46E+06	mm <sup>4</sup>	
Torsion modulus	$J$	=	2.78E+06	mm <sup>3</sup>	
Elastic section modulus	$Z$	=	41441.7	mm <sup>3</sup>	
Slenderness	$S$	=	90.67		
Limit 1	$S_1$	=	21.80		
Limit 2	$S_2$	=	3854.05		
Factored limit state stress	$\phi F_L$	=	<b>95.00</b>	<b>MPa</b>	3.4.15(2)
<b>3.4.17</b> <i>Compression in components of beams (component under uniform compression), gross section - flat plates with both edges supported</i>					
	$k_1$	=	0.5		T3.3(D)
	$k_2$	=	2.04		T3.3(D)
Max. distance between toes of fillets of supporting elements for plate	$b'$	=	79	mm	
	$t$	=	3	mm	
Slenderness	$b/t$	=	26.333333		
Limit 1	$S_1$	=	12.06		
Limit 2	$S_2$	=	71.35		
Factored limit state stress	$\phi F_L$	=	<b>93.08</b>	<b>MPa</b>	
Most adverse in-plane bending limit state stress	$F_{bx}$	=	93.08	MPa	
Most adverse in-plane bending capacity factor	$f_{bx}/F_{bx}$	=	0.21		PASS

BENDING - OUT-OF-PLANE				
<i>NOTE: Limit state stresses, <math>\phi F_L</math> are the same for out-of-plane bending (doubly symmetric section)</i>				
Factored limit state stress	$\phi F_L$	=	<b>93.08</b>	<b>MPa</b>
Most adverse out-of-plane bending limit state stress	$F_{by}$	=	93.08	MPa
Most adverse out-of-plane bending capacity factor	$f_{by}/F_{by}$	=	0.07	PASS
COMBINED ACTIONS				
<b>4.1.1 Combined compression and bending</b>				
				... 4.1.1(2)
	$F_a$	=	73.54	MPa ... 3.4.8
	$F_{ao}$	=	93.08	MPa ... 3.4.10
	$F_{bx}$	=	93.08	MPa ... 3.4.17
	$F_{by}$	=	93.08	MPa ... 3.4.17
	$f_a/F_a$	=	0.006	
	Check: $f_a/F_a + f_{bx}/F_{bx} + f_{by}/F_{by} \leq 1.0$			... 4.1.1 (3)
	i.e. 0.29	$\leq$	1.0	PASS
SHEAR				
<b>3.4.24 Shear in webs (Major Axis)</b>				
				... 4.1.1(2)
Clear web height	$h$	=	114	mm
	$t$	=	3	mm
Slenderness	$h/t$	=	38	
Limit 1	$S_1$	=	33.38	
Limit 2	$S_2$	=	59.31	
Factored limit state stress	$\phi F_L$	=	<b>57.60</b>	<b>MPa</b>
Stress From Shear force	$f_{sx}$	=	$V/A_w$	
			<b>0.00</b>	<b>MPa</b>
<b>3.4.25 Shear in webs (Minor Axis)</b>				
Clear web height	$b$	=	79	mm
	$t$	=	3	mm
Slenderness	$b/t$	=	26.333333	
Factored limit state stress	$\phi F_L$	=	<b>58.90</b>	<b>MPa</b>
Stress From Shear force	$f_{sy}$	=	$V/A_w$	



			<b>0.05</b>	<b>MPa</b>		
Most adverse shear capacity factor (Major Axis)	$f_{sx}/F_{sx}$	=	0.00	<b>MPa</b>		
Most adverse shear capacity factor (Minor Axis)	$f_{sy}/F_{sy}$	=	0.00	<b>Mpa</b>	PASS	
<b>COMBINED ACTIONS</b>						
<b>4.4 Combined Shear, Compression and bending</b>						
Check: $f_a/F_a + f_b/F_b + (f_s/F_s)^2 \leq 1.0$						
i.e. 0.22 ≤ 1.0						
					PASS	

### 11.1.2 Cantilever Beam



Job no.

21-174-2

Date:

17/01/2022

NAME	SYMBOL	VALUE	UNIT	NOTES	REF
<b>60x35x3.5</b>	<b>Cantilever Beam</b>				
Alloy and temper	6063-T5				AS1664.1
Tension	$F_{tu}$	=	152	MPa	Ultimate Yield
	$F_{ty}$	=	110	MPa	
Compression	$F_{cy}$	=	110	MPa	Ultimate Yield
	$F_{su}$	=	90	MPa	
Shear	$F_{sy}$	=	62	MPa	Ultimate Yield
	$F_{bu}$	=	317	MPa	
Bearing	$F_{by}$	=	179	MPa	Ultimate Yield
Modulus of elasticity	$E$	=	70000	MPa	Compressive
	$k_t$	=	1		
	$k_c$	=	1		
<b>FEM ANALYSIS RESULTS</b>					
Axial force	$P$	=	0.057	kN	compression Tension
	$P$	=	0	kN	

In plane moment	$M_x$	=	0.3859	kNm		
Out of plane moment	$M_y$	=	0.1841	kNm		
<b>DESIGN STRESSES</b>						
Gross cross section area	$A_g$	=	616	mm <sup>2</sup>		
In-plane elastic section modulus	$Z_x$	=	9420.677 8	mm <sup>3</sup>		
Out-of-plane elastic section mod.	$Z_y$	=	6709.733 3	mm <sup>3</sup>		
Stress from axial force	$f_a$	=	$P/A_g$			
		=	<b>0.09</b>	<b>MPa</b>	compression	
		=	<b>0.00</b>	<b>MPa</b>	Tension	
Stress from in-plane bending	$f_{bx}$	=	$M_x/Z_x$			
		=	<b>40.96</b>	<b>MPa</b>	compression	
Stress from out-of-plane bending	$f_{by}$	=	$M_y/Z_y$			
		=	<b>27.44</b>	<b>MPa</b>	compression	
<b>Tension</b>						
<b>3.4.3 Tension in rectangular tubes</b>						
	$\phi F_L$	=	<b>104.50</b>	<b>MPa</b>		
		<b>O</b>				
		<b>R</b>				
	$\phi F_L$	=	<b>129.20</b>	<b>MPa</b>		
<b>COMPRESSION</b>						
<b>3.4.8 Compression in columns, axial, gross section</b>						
<b>1. General</b>						
						... 3.4.8.1
Unsupported length of member	$L$	=	1850	mm		
Effective length factor	$k$	=	1.00			
Radius of gyration about buckling axis (Y)	$r_y$	=	13.81	mm		
Radius of gyration about buckling axis (X)	$r_x$	=	21.42	mm		
Slenderness ratio	$kLb/r_y$	=	68.81			
Slenderness ratio	$kL/r_x$	=	86.37			
Slenderness parameter	$\lambda$	=	1.09			
	$D_c^*$	=	39.0			
	$S_1^*$	=	0.24			
	$S_2^*$	=	1.25			
	$\phi_{cc}$	=	0.771			
Factored limit state stress	$\phi F_L$	=	<b>59.18</b>	<b>MPa</b>		

2. Sections not subject to torsional or torsional-flexural buckling Largest slenderness ratio for flexural buckling			$kL/r = 86.37$	... 3.4.8.2
<b>3.4.10 Uniform compression in components of columns, gross section - flat plates</b> 1. Uniform compression in components of columns, gross section - flat plates with both edges supported			$k_1 = 0.35$	... 3.4.10.1 T3.3(D)
Max. distance between toes of fillets of supporting elements for plate	$b'$	$=$	28	
	$t$	$=$	3.5 mm	
Slenderness	$b/t$	$=$	8	
Limit 1	$S_1$	$=$	12.06	
Limit 2	$S_2$	$=$	49.94	
Factored limit state stress	$\phi F_L$	$=$	<b>104.50 MPa</b>	
Most adverse compressive limit state stress	$F_a$	$=$	59.18 MPa	
Most adverse tensile limit state stress	$F_a$	$=$	104.50 MPa	
Most adverse compressive & Tensile capacity factor	$f_a/F_a$	$=$	0.00	PASS
<b>BENDING - IN-PLANE</b>				
<b>3.4.15 Compression in beams, extreme fibre, gross section rectangular tubes, box sections</b>				
Unbraced length for bending	$L_b$	$=$	950 mm	
Second moment of area (weak axis)	$I_y$	$=$	1.17E+05 mm <sup>4</sup>	
Torsion modulus	$J$	$=$	2.52E+05 mm <sup>3</sup>	
Elastic section modulus	$Z$	$=$	9420.677 mm <sup>3</sup>	
Slenderness	$S$	$=$	104.06	
Limit 1	$S_1$	$=$	21.80	
Limit 2	$S_2$	$=$	3854.05	
Factored limit state stress	$\phi F_L$	$=$	<b>94.54 MPa</b>	... 3.4.15(2)
<b>3.4.17 Compression in components of beams (component under uniform compression), gross section - flat plates with both edges supported</b>				
	$k_1$	$=$	0.5	T3.3(D)
	$k_2$	$=$	2.04	T3.3(D)



Max. distance between toes of fillets of supporting elements for plate	$b'$	=	28	mm		
	$t$	=	3.5	mm		
Slenderness	$b/t$	=	8			
Limit 1	$S_1$	=	12.06			
Limit 2	$S_2$	=	71.35			
Factored limit state stress	$\phi F_L$	=	104.50	MPa		
Most adverse in-plane bending limit state stress	$F_{bx}$	=	94.54	MPa		
Most adverse in-plane bending capacity factor	$f_{bx}/F_{bx}$	=	0.43		PASS	
<b>BENDING - OUT-OF-PLANE</b>						
<i>NOTE: Limit state stresses, <math>\phi F_L</math> are the same for out-of-plane bending (doubly symmetric section)</i>						
Factored limit state stress	$\phi F_L$	=	94.54	MPa		
Most adverse out-of-plane bending limit state stress	$F_{by}$	=	94.54	MPa		
Most adverse out-of-plane bending capacity factor	$f_{by}/F_{by}$	=	0.29		PASS	
<b>COMBINED ACTIONS</b>						
<b>4.1.1 Combined compression and bending</b>						
						...
						4.1.1(2)
	$F_a$	=	59.18	MPa		... 3.4.8
	$F_{ao}$	=	104.50	MPa		... 3.4.10
	$F_{bx}$	=	94.54	MPa		... 3.4.17
	$F_{by}$	=	94.54	MPa		... 3.4.17
	$f_a/F_a$	=	0.002			
	Check: $f_a/F_a + f_{bx}/F_{bx} + f_{by}/F_{by} \leq 1.0$					... 4.1.1 (3)
	i.e. 0.73	$\leq$	1.0		PASS	
<b>SHEAR</b>						
<b>3.4.24 Shear in webs (Major Axis)</b>						
						...
						4.1.1(2)
Clear web height	$h$	=	53	mm		
	$t$	=	3.5	mm		

Slenderness	$h/t$	=	15.14285		
			7		
Limit 1	$S_1$	=	33.38		
Limit 2	$S_2$	=	59.31		
Factored limit state stress	$\phi F_L$	=	<b>58.90</b>	<b>MPa</b>	
Stress From Shear force	$f_{sx}$	=	$V/A_w$		
			<b>0.93</b>	<b>MPa</b>	
<b>3.4.25 Shear in webs (Minor Axis)</b>					
Clear web height	$b$	=	28	mm	
	$t$	=	3.5	mm	
Slenderness	$b/t$	=	8		
Factored limit state stress	$\phi F_L$	=	<b>58.90</b>	<b>MPa</b>	
Stress From Shear force	$f_{sy}$	=	$V/A_w$		
			<b>0.64</b>	<b>MPa</b>	
Most adverseshear capacity factor (Major Axis)	$f_{sx}/F_{sx}$	=	0.02	<b>MPa</b>	
Most adverseshear capacity factor (Minor Axis)	$f_{sy}/F_{sy}$	=	0.01	<b>Mpa</b>	PASS
<b>COMBINED ACTIONS</b>					
<b>4.4 Combined Shear, Compression and bending</b>					
Check: $f_a/F_a + f_b/F_b + (f_s/F_s)^2 \leq 1.0$					
i.e.      0.44 $\leq$ 1.0					
PASS					

### 11.1.3 Brace (typ.1)

NAME	SYMBOL	VALUE	UNIT	NOTES	REF
<b>60x35x3.5</b>	<b>Brace 1</b>				
Alloy and temper	6063-T5				AS1664.1
Tension	$F_{tu}$	=	152	MPa	Ultimate
	$F_{ty}$	=	110	MPa	Yield
Compression	$F_{cy}$	=	110	MPa	

Shear	$F_{su}$	=	90	MPa	<i>Ultimate</i>	T3.4(B)	
	$F_{sy}$	=	62	MPa	<i>Yield</i>		
Bearing	$F_{bu}$	=	317	MPa	<i>Ultimate</i>		
	$F_{by}$	=	179	MPa	<i>Yield</i>		
Modulus of elasticity	$E$	=	70000	MPa	<i>Compressive</i>		
	$k_t$	=	1				
	$k_c$	=	1				
<b>FEM ANALYSIS RESULTS</b>							
Axial force	$P$	=	0.117	kN	<i>compression</i>		
	$P$	=	0	kN	<i>Tension</i>		
In plane moment	$M_x$	=	7.227E-19	kNm			
Out of plane moment	$M_y$	=	0.2362	kNm			
<b>DESIGN STRESSES</b>							
Gross cross section area	$A_g$	=	616	mm <sup>2</sup>			
In-plane elastic section modulus	$Z_x$	=	9420.6778	mm <sup>3</sup>			
Out-of-plane elastic section mod.	$Z_y$	=	6709.7333	mm <sup>3</sup>			
Stress from axial force	$f_a$	=	$P/A_g$				
		=	<b>0.19</b>	<b>MPa</b>	<i>compression</i>		
		=	<b>0.00</b>	<b>MPa</b>	<i>Tension</i>		
Stress from in-plane bending	$f_{bx}$	=	$M_x/Z_x$				
		=	<b>0.00</b>	<b>MPa</b>	<i>compression</i>		
		=					
Stress from out-of-plane bending	$f_{by}$	=	$M_y/Z_y$				
		=	<b>35.20</b>	<b>MPa</b>	<i>compression</i>		
		=					
<b>Tension</b>							
<b>3.4.3 Tension in rectangular tubes</b>							
	$\phi F_L$	=	<b>104.50</b>	<b>MPa</b>			
		<b>OR</b>					
	$\phi F_L$	=	<b>129.20</b>	<b>MPa</b>			
<b>COMPRESSION</b>							
<b>3.4.8 Compression in columns, axial, gross section</b>							
<b>1. General</b>							
Unsupported length of member	$L$	=	1000	mm			
Effective length factor	$k$	=	1.00				
Radius of gyration about buckling axis (Y)	$r_y$	=	13.81	mm			
					... 3.4.8.1		

Radius of gyration about buckling axis (X)	$r_x$	=	21.42	mm		
Slenderness ratio	$kL_b/r_y$	=	72.43			
Slenderness ratio	$kL/r_x$	=	46.69			
Slenderness parameter	$\lambda$	=	0.91			
	$D_c^*$	=	39.0			
	$S_1^*$	=	0.24			
	$S_2^*$	=	1.25			
	$\phi_{cc}$	=	0.808			
Factored limit state stress	$\phi F_L$	=	<b>67.56</b>	<b>MPa</b>		
<i>2. Sections not subject to torsional or torsional-flexural buckling</i>						... 3.4.8.2
Largest slenderness ratio for flexural buckling	$kL/r$	=	72.43			
<b>3.4.10 Uniform compression in components of columns, gross section - flat plates</b>						
<i>1. Uniform compression in components of columns, gross section - flat plates with both edges supported</i>						... 3.4.10.1
	$k_1$	=	0.35			T3.3(D)
Max. distance between toes of fillets of supporting elements for plate	$b'$	=	28			
	$t$	=	3.5	mm		
Slenderness	$b/t$	=	8			
Limit 1	$S_1$	=	12.06			
Limit 2	$S_2$	=	49.94			
Factored limit state stress	$\phi F_L$	=	<b>104.50</b>	<b>MPa</b>		
Most adverse compressive limit state stress	$F_a$	=	67.56	MPa		
Most adverse tensile limit state stress	$F_a$	=	104.50	MPa		
Most adverse compressive & Tensile capacity factor	$f_a/F_a$	=	0.00		PASS	
<b>BENDING - IN-PLANE</b>						
<b>3.4.15 Compression in beams, extreme fibre, gross section rectangular tubes, box sections</b>						
Unbraced length for bending	$L_b$	=	1000	mm		
Second moment of area (weak axis)	$I_y$	=	117420.33	mm <sup>4</sup>		

Torsion modulus	J	=	251961.03	mm <sup>3</sup>		
Elastic section modulus	Z	=	9420.6778	mm <sup>3</sup>		
Slenderness	S	=	109.54			
Limit 1	S <sub>1</sub>	=	21.80			
Limit 2	S <sub>2</sub>	=	3854.05			
Factored limit state stress	$\phi F_L$	=	<b>94.37</b>	<b>MPa</b>		3.4.15(2)
<b>3.4.17 Compression in components of beams (component under uniform compression), gross section - flat plates with both edges supported</b>						
	k <sub>1</sub>	=	0.5			T3.3(D)
	k <sub>2</sub>	=	2.04			T3.3(D)
Max. distance between toes of fillets of supporting elements for plate	b'	=	<b>28</b>	mm		
	t	=	3.5	mm		
Slenderness	b/t	=	8			
Limit 1	S <sub>1</sub>	=	12.06			
Limit 2	S <sub>2</sub>	=	71.35			
Factored limit state stress	$\phi F_L$	=	<b>104.50</b>	<b>MPa</b>		
Most adverse in-plane bending limit state stress	F <sub>bx</sub>	=	94.37	MPa		
Most adverse in-plane bending capacity factor	f <sub>bx</sub> /F <sub>bx</sub>	=	0.00		PASS	
<b>BENDING - OUT-OF-PLANE</b>						
<i>NOTE: Limit state stresses, <math>\phi F_L</math> are the same for out-of-plane bending (doubly symmetric section)</i>						
Factored limit state stress	$\phi F_L$	=	<b>94.37</b>	<b>MPa</b>		
Most adverse out-of-plane bending limit state stress	F <sub>by</sub>	=	94.37	MPa		
Most adverse out-of-plane bending capacity factor	f <sub>by</sub> /F <sub>by</sub>	=	0.37		PASS	
<b>COMBINED ACTIONS</b>						
<b>4.1.1 Combined compression and bending</b>						
	F <sub>a</sub>	=	67.56	MPa		... 4.1.1(2)
	F <sub>ao</sub>	=	104.50	MPa		... 3.4.8
						... 3.4.10

	$F_{bx}$	=	94.37	MPa		... 3.4.17
	$F_{by}$	=	94.37	MPa		... 3.4.17
	$f_a/F_a$	=	0.003			
	Check:	$f_a/F_a + f_{bx}/F_{bx} + f_{by}/F_{by} \leq 1.0$				... 4.1.1 (3)
	i.e.	0.38	$\leq$	1.0	PASS	
<b>SHEAR</b>						
<b>3.4.24 Shear in webs (Major Axis)</b>						
						... 4.1.1(2)
Clear web height	$h$	=	53	mm		
	$t$	=	3.5	mm		
Slenderness	$h/t$	=	15.142857			
Limit 1	$S_1$	=	33.38			
Limit 2	$S_2$	=	59.31			
Factored limit state stress	$\phi F_L$	=	58.90	MPa		
Stress From Shear force	$f_{sx}$	=	$V/A_w$			
			0.02	MPa		
<b>3.4.25 Shear in webs (Minor Axis)</b>						
Clear web height	$b$	=	28	mm		
	$t$	=	3.5	mm		
Slenderness	$b/t$	=	8			
Factored limit state stress	$\phi F_L$	=	58.90	MPa		
Stress From Shear force	$f_{sy}$	=	$V/A_w$			
			0.73	MPa		
Most adverseshear capacity factor (Major Axis)	$f_{sx}/F_{sx}$	=	0.00	MPa		
Most adverseshear capacity factor (Minor Axis)	$f_{sy}/F_{sy}$	=	0.01	Mpa	PASS	
<b>COMBINED ACTIONS</b>						
<b>4.4 Combined Shear, Compression and bending</b>						
	Check:	$f_a/F_a + f_b/F_b + (f_s/F_s)^2 \leq 1.0$				
	i.e.	0.38	$\leq$	1.0	PASS	

### 11.1.4 Brace (typ.2)



Job no. 21-174-2

Date: 17/01/2022

NAME	SYMBOL	VALUE	UNIT	NOTES	REF
<b>30x20x1.5</b>	<b>Brace 2</b>				
Alloy and temper	6063-T5				AS1664.1
Tension	$F_{tu}$	= 152	MPa	Ultimate	T3.3(A)
	$F_{ty}$	= 110	MPa	Yield	
Compression	$F_{cy}$	= 110	MPa		
Shear	$F_{su}$	= 90	MPa	Ultimate	
	$F_{sy}$	= 62	MPa	Yield	
Bearing	$F_{bu}$	= 317	MPa	Ultimate	
	$F_{by}$	= 179	MPa	Yield	
Modulus of elasticity	$E$	= 70000	MPa	Compressive	
	$k_t$	= 1			T3.4(B)
	$k_c$	= 1			
<b>FEM ANALYSIS RESULTS</b>					
Axial force	$P$	= 0.272	kN	compression	
	$P$	= 0	kN	Tension	
In plane moment	$M_x$	= 0	kNm		
Out of plane moment	$M_y$	= 0.0154	kNm		
<b>DESIGN STRESSES</b>					
Gross cross section area	$A_g$	= 141	mm <sup>2</sup>		
In-plane elastic section modulus	$Z_x$	= 1141.05	mm <sup>3</sup>		
Out-of-plane elastic section mod.	$Z_y$	= 894.575	mm <sup>3</sup>		
Stress from axial force	$f_a$	= $P/A_g$			
		= 1.93	MPa	compression	
		= 0.00	MPa	Tension	
Stress from in-plane bending	$f_{bx}$	= $M_x/Z_x$			
		= 0.00	MPa	compression	
	$f_{by}$	= $M_y/Z_y$			

Stress from out-of-plane bending	=	17.21	MPa	<i>compression</i>	
<i>Tension</i>					
<b>3.4.3 Tension in rectangular tubes</b>					
	$\phi F_L$	=	104.50	MPa	
		OR			
	$\phi F_L$	=	129.20	MPa	
<b>COMPRESSION</b>					
<b>3.4.8 Compression in columns, axial, gross section</b>					
1. General					
					... 3.4.8.1
Unsupported length of member	L	=	1000	mm	
Effective length factor	k	=	1.00		
Radius of gyration about buckling axis (Y)	$r_y$	=	7.97	mm	
Radius of gyration about buckling axis (X)	$r_x$	=	11.02	mm	
Slenderness ratio	$kLb/r_y$	=	125.55		
Slenderness ratio	$kL/r_x$	=	90.76		
Slenderness parameter	$\lambda$	=	1.58		
	$D_c^*$	=	39.0		
	$S_1^*$	=	0.24		
	$S_2^*$	=	1.25		
	$\phi_{cc}$	=	0.802		
Factored limit state stress	$\phi F_L$	=	35.14	MPa	
2. Sections not subject to torsional or torsional-flexural buckling					
					... 3.4.8.2
Largest slenderness ratio for flexural buckling	$kL/r$	=	125.55		
<b>3.4.10 Uniform compression in components of columns, gross section - flat plates</b>					
1. Uniform compression in components of columns, gross section - flat plates with both edges supported					
					...
	$k_1$	=	0.35		3.4.10.1
					T3.3(D)
Max. distance between toes of fillets of supporting elements for plate	$b'$	=	17		
	t	=	1.5	mm	
Slenderness	$b/t$	=	11.333333		
Limit 1	$S_1$	=	12.06		
Limit 2	$S_2$	=	49.94		



Factored limit state stress	$\phi F_L$	=	<b>104.50</b>	<b>MPa</b>	
Most adverse compressive limit state stress	$F_a$	=	35.14	MPa	
Most adverse tensile limit state stress	$F_a$	=	104.50	MPa	
Most adverse compressive & Tensile capacity factor	$f_a/F_a$	=	0.05		PASS
<b>BENDING - IN-PLANE</b>					
<b>3.4.15</b> <i>Compression in beams, extreme fibre, gross section rectangular tubes, box sections</i>					
Unbraced length for bending	$L_b$	=	1000	mm	
Second moment of area (weak axis)	$I_y$	=	8945.75	mm <sup>4</sup>	
Torsion modulus	$J$	=	17744.206	mm <sup>3</sup>	
Elastic section modulus	$Z$	=	1141.05	mm <sup>3</sup>	
Slenderness	$S$	=	181.13		
Limit 1	$S_1$	=	21.80		
Limit 2	$S_2$	=	3854.05		
Factored limit state stress	$\phi F_L$	=	<b>92.36</b>	<b>MPa</b>	3.4.15(2)
<b>3.4.17</b> <i>Compression in components of beams (component under uniform compression), gross section - flat plates with both edges supported</i>					
	$k_1$	=	0.5		T3.3(D)
	$k_2$	=	2.04		T3.3(D)
Max. distance between toes of fillets of supporting elements for plate	$b'$	=	17	mm	
	$t$	=	1.5	mm	
Slenderness	$b/t$	=	11.333333		
Limit 1	$S_1$	=	12.06		
Limit 2	$S_2$	=	71.35		
Factored limit state stress	$\phi F_L$	=	<b>104.50</b>	<b>MPa</b>	
Most adverse in-plane bending limit state stress	$F_{bx}$	=	92.36	MPa	
Most adverse in-plane bending capacity factor	$f_{bx}/F_{bx}$	=	0.00		PASS

BENDING - OUT-OF-PLANE					
NOTE: Limit state stresses, $\phi F_L$ are the same for out-of-plane bending (doubly symmetric section)					
Factored limit state stress	$\phi F_L$	=	<b>92.36</b>	<b>MPa</b>	
Most adverse out-of-plane bending limit state stress	$F_{by}$	=	92.36	MPa	
Most adverse out-of-plane bending capacity factor	$f_{by}/F_{by}$	=	0.19		PASS
COMBINED ACTIONS					
<b>4.1.1 Combined compression and bending</b>					
	$F_a$	=	35.14	MPa	... 4.1.1(2)
	$F_{ao}$	=	104.50	MPa	... 3.4.8
	$F_{bx}$	=	92.36	MPa	... 3.4.10
	$F_{by}$	=	92.36	MPa	... 3.4.17
	$f_a/F_a$	=	0.055		... 3.4.17
Check:	$f_a/F_a + f_{bx}/F_{bx} + f_{by}/F_{by} \leq 1.0$				... 4.1.1 (3)
i.e.	0.24	≤	1.0		PASS
SHEAR					
<b>3.4.24 Shear in webs (Major Axis)</b>					
					... 4.1.1(2)
Clear web height	$h$	=	27	mm	
	$t$	=	1.5	mm	
Slenderness	$h/t$	=	18		
Limit 1	$S_1$	=	33.38		
Limit 2	$S_2$	=	59.31		
Factored limit state stress	$\phi F_L$	=	<b>58.90</b>	<b>MPa</b>	
Stress From Shear force	$f_{sx}$	=	$V/A_w$		
			<b>0.01</b>	<b>MPa</b>	
<b>3.4.25 Shear in webs (Minor Axis)</b>					
Clear web height	$b$	=	17	mm	
	$t$	=	1.5	mm	
Slenderness	$b/t$	=	11.333333		
Factored limit state stress	$\phi F_L$	=	<b>58.90</b>	<b>MPa</b>	
Stress From Shear force	$f_{sy}$	=	$V/A_w$		



			<b>0.22</b>	<b>MPa</b>		
Most adverseshear capacity factor (Major Axis)	$f_{sx}/F_{sx}$	=	0.00	<b>MPa</b>		
Most adverseshear capacity factor (Minor Axis)	$f_{sy}/F_{sy}$	=	0.00	<b>Mpa</b>	PASS	
<b>COMBINED ACTIONS</b>						
<b>4.4 Combined Shear, Compression and bending</b>						
Check: $f_a/F_a + f_b/F_b + (f_s/F_s)^2 \leq 1.0$						
i.e. 0.24 ≤ 1.0						
					PASS	

### 11.1.5 Middle Beam



Job no.

21-174-2

Date:

17/01/2022

NAME	SYMBOL	VALUE	UNIT	NOTES	REF
<b>30x20x1.5</b>	<b>Middle Beam</b>				
Alloy and temper	6063-T5				AS1664.1
Tension	$F_{tu}$	=	152	MPa	Ultimate
	$F_{ty}$	=	110	MPa	Yield
Compression	$F_{cy}$	=	110	MPa	
Shear	$F_{su}$	=	90	MPa	Ultimate
	$F_{sy}$	=	62	MPa	Yield
Bearing	$F_{bu}$	=	317	MPa	Ultimate
	$F_{by}$	=	179	MPa	Yield
Modulus of elasticity	E	=	70000	MPa	Compressive
	$k_t$	=	1		
	$k_c$	=	1		T3.4(B)
<b>FEM ANALYSIS RESULTS</b>					
Axial force	P	=	0	kN	compression
	P	=	0.162	kN	Tension
In plane moment	$M_x$	=	0.0477	kNm	

Out of plane moment	$M_y$	=	0.0018	kNm		
<b>DESIGN STRESSES</b>						
Gross cross section area	$A_g$	=	141	mm <sup>2</sup>		
In-plane elastic section modulus	$Z_x$	=	1141.05	mm <sup>3</sup>		
Out-of-plane elastic section mod.	$Z_y$	=	894.575	mm <sup>3</sup>		
Stress from axial force	$f_a$	=	$P/A_g$			
		=	<b>0.00</b>	<b>MPa</b>	<i>compression</i>	
		=	<b>1.15</b>	<b>MPa</b>	<i>Tension</i>	
Stress from in-plane bending	$f_{bx}$	=	$M_x/Z_x$			
		=	<b>41.80</b>	<b>MPa</b>	<i>compression</i>	
Stress from out-of-plane bending	$f_{by}$	=	$M_y/Z_y$			
		=	<b>2.01</b>	<b>MPa</b>	<i>compression</i>	
<b>Tension</b>						
<b>3.4.3 Tension in rectangular tubes</b>						
	$\phi F_L$	=	<b>104.50</b>	<b>MPa</b>		
		OR				
	$\phi F_L$	=	<b>129.20</b>	<b>MPa</b>		
<b>COMPRESSION</b>						
<b>3.4.8 Compression in columns, axial, gross section</b>						
<b>1. General</b>						
Unsupported length of member	L	=	2040	mm		... 3.4.8.1
Effective length factor	k	=	1.00			
Radius of gyration about buckling axis (Y)	$r_y$	=	7.97	mm		
Radius of gyration about buckling axis (X)	$r_x$	=	11.02	mm		
Slenderness ratio	$kLb/r_y$	=	130.57			
Slenderness ratio	$kL/r_x$	=	185.16			
Slenderness parameter	$\lambda$	=	2.34			
	$D_c^*$	=	39.0			
	$S_1^*$	=	0.24			
	$S_2^*$	=	1.25			
	$\phi_{cc}$	=	0.907			
Factored limit state stress	$\phi F_L$	=	<b>18.28</b>	<b>MPa</b>		
<b>2. Sections not subject to torsional or torsional-flexural buckling</b>						
Largest slenderness ratio for flexural buckling	$kL/r$	=	185.16			... 3.4.8.2

<b>3.4.10 Uniform compression in components of columns, gross section - flat plates</b>					
<i>1. Uniform compression in components of columns, gross section - flat plates with both edges supported</i>					...
	$k_1$	=	0.35		T3.3(D)
Max. distance between toes of fillets of supporting elements for plate	$b'$	=	17		
	$t$	=	1.5 mm		
Slenderness	$b/t$	=	11.333333		
Limit 1	$S_1$	=	12.06		
Limit 2	$S_2$	=	49.94		
Factored limit state stress	$\phi F_L$	=	<b>104.50 MPa</b>		
Most adverse compressive limit state stress	$F_a$	=	18.28 MPa		
Most adverse tensile limit state stress	$F_a$	=	104.50 MPa		
Most adverse compressive & Tensile capacity factor	$f_a/F_a$	=	0.01	PASS	
<b>BENDING - IN-PLANE</b>					
<b>3.4.15 Compression in beams, extreme fibre, gross section rectangular tubes, box sections</b>					
Unbraced length for bending	$L_b$	=	1040 mm		
Second moment of area (weak axis)	$I_y$	=	8945.75 mm <sup>4</sup>		
Torsion modulus	$J$	=	17744.206 mm <sup>3</sup>		
Elastic section modulus	$Z$	=	1141.05 mm <sup>3</sup>		
Slenderness	$S$	=	188.38		
Limit 1	$S_1$	=	21.80		
Limit 2	$S_2$	=	3854.05		
Factored limit state stress	$\phi F_L$	=	<b>92.19 MPa</b>		3.4.15(2)
<b>3.4.17 Compression in components of beams (component under uniform compression), gross section - flat plates with both edges supported</b>					
	$k_1$	=	0.5		T3.3(D)
	$k_2$	=	2.04		T3.3(D)

Max. distance between toes of fillets of supporting elements for plate	$b'$	=	17	mm		
	$t$	=	1.5	mm		
Slenderness	$b/t$	=	11.333333			
Limit 1	$S_1$	=	12.06			
Limit 2	$S_2$	=	71.35			
Factored limit state stress	$\phi F_L$	=	104.50	MPa		
Most adverse in-plane bending limit state stress	$F_{bx}$	=	92.19	MPa		
Most adverse in-plane bending capacity factor	$f_{bx}/F_{bx}$	=	0.45		PASS	
<b>BENDING - OUT-OF-PLANE</b>						
<i>NOTE: Limit state stresses, <math>\phi F_L</math> are the same for out-of-plane bending (doubly symmetric section)</i>						
Factored limit state stress	$\phi F_L$	=	92.19	MPa		
Most adverse out-of-plane bending limit state stress	$F_{by}$	=	92.19	MPa		
Most adverse out-of-plane bending capacity factor	$f_{by}/F_{by}$	=	0.02		PASS	
<b>COMBINED ACTIONS</b>						
<b>4.1.1 Combined compression and bending</b>						
	$F_a$	=	18.28	MPa		... 4.1.1(2)
	$F_{ao}$	=	104.50	MPa		... 3.4.8
	$F_{bx}$	=	92.19	MPa		... 3.4.10
	$F_{by}$	=	92.19	MPa		... 3.4.17
	$f_a/F_a$	=	0.011			... 3.4.17
Check:	$f_a/F_a + f_{bx}/F_{bx} + f_{by}/F_{by} \leq 1.0$					... 4.1.1 (3)
i.e.	0.49	$\leq$	1.0		PASS	
<b>SHEAR</b>						
<b>3.4.24 Shear in webs (Major Axis)</b>						
	$h$	=	27	mm		... 4.1.1(2)
	$t$	=	1.5	mm		
Slenderness	$h/t$	=	18			

Limit 1	$S_1$	=	33.38		
Limit 2	$S_2$	=	59.31		
Factored limit state stress	$\phi F_L$	=	<b>58.90</b>	<b>MPa</b>	
Stress From Shear force	$f_{sx}$	=	$V/A_w$		
			<b>0.59</b>	<b>MPa</b>	
<b>3.4.25 Shear in webs (Minor Axis)</b>					
Clear web height	b	=	17	mm	
	t	=	1.5	mm	
Slenderness	b/t	=	11.333333		
Factored limit state stress	$\phi F_L$	=	<b>58.90</b>	<b>MPa</b>	
Stress From Shear force	$f_{sy}$	=	$V/A_w$		
			<b>0.10</b>	<b>MPa</b>	
Most adverseshear capacity factor (Major Axis)	$f_{sx}/F_{sx}$	=	0.01	<b>MPa</b>	
Most adverseshear capacity factor (Minor Axis)	$f_{sy}/F_{sy}$	=	0.00	<b>Mpa</b>	PASS
<b>COMBINED ACTIONS</b>					
<b>4.4 Combined Shear, Compression and bending</b>					
Check: $f_a/F_a + f_b/F_b + (f_s/F_s)^2 \leq 1.0$					
i.e. 0.46 ≤ 1.0					
					PASS

### 11.1.6 Corner Beam



Job no.

21-174-2

Date:

17/01/2022

NAME	SYMBOL	VALUE	UNIT	NOTES	REF
<b>30x20x1.5</b>	<b>Corner Beam</b>				
Alloy and temper	6063-T5				AS1664.1
Tension	$F_{tu}$	=	152	MPa	Ultimate
	$F_{ty}$	=	110	MPa	Yield
Compression	$F_{cy}$	=	110	MPa	
Shear	$F_{su}$	=	90	MPa	Ultimate

Bearing	$F_{sy}$	=	62	MPa	Yield	
	$F_{bu}$	=	317	MPa	Ultimate	
	$F_{by}$	=	179	MPa	Yield	
Modulus of elasticity	E	=	70000	MPa	Compressive	
	$k_t$	=	1			T3.4(B)
	$k_c$	=	1			
<b>FEM ANALYSIS RESULTS</b>						
Axial force	P	=	0	kN	compression	
	P	=	0.201	kN	Tension	
In plane moment	$M_x$	=	0.0788	kNm		
Out of plane moment	$M_y$	=	0.0062	kNm		
<b>DESIGN STRESSES</b>						
Gross cross section area	$A_g$	=	141	mm <sup>2</sup>		
In-plane elastic section modulus	$Z_x$	=	1141.05	mm <sup>3</sup>		
Out-of-plane elastic section mod.	$Z_y$	=	894.575	mm <sup>3</sup>		
Stress from axial force	$f_a$	=	$P/A_g$			
		=	<b>0.00</b>	<b>MPa</b>	compression	
		=	<b>1.43</b>	<b>MPa</b>	Tension	
Stress from in-plane bending	$f_{bx}$	=	$M_x/Z_x$			
		=	<b>69.06</b>	<b>MPa</b>	compression	
Stress from out-of-plane bending	$f_{by}$	=	$M_y/Z_y$			
		=	<b>6.93</b>	<b>MPa</b>	compression	
<b>Tension</b>						
<b>3.4.3 Tension in rectangular tubes</b>						
	$\phi F_L$	=	<b>104.50</b>	<b>MPa</b>		
		<b>O</b>				
		<b>R</b>				
	$\phi F_L$	=	<b>129.20</b>	<b>MPa</b>		
<b>COMPRESSION</b>						
<b>3.4.8 Compression in columns, axial, gross section</b>						
<b>1. General</b>						
						... 3.4.8.1
Unsupported length of member	L	=	2820	mm		
Effective length factor	k	=	1.00			
Radius of gyration about buckling axis (Y)	$r_y$	=	7.97	mm		



Radius of gyration about buckling axis (X)	$r_x$	=	11.02	mm		
Slenderness ratio	$kLb/ry$	=	232.26			
Slenderness ratio	$kL/r_x$	=	255.95			
Slenderness parameter	$\lambda$	=	3.23			
	$D_c^*$	=	39.0			
	$S_1^*$	=	0.24			
	$S_2^*$	=	1.25			
	$\phi_{cc}$	=	0.950			
Factored limit state stress	$\phi F_L$	=	<b>10.02</b>	<b>MPa</b>		
<i>2. Sections not subject to torsional or torsional-flexural buckling</i>						
Largest slenderness ratio for flexural buckling	$kL/r$	=	255.95			... 3.4.8.2
<b>3.4.10 Uniform compression in components of columns, gross section - flat plates</b>						
<i>1. Uniform compression in components of columns, gross section - flat plates with both edges supported</i>						
	$k_1$	=	0.35			...
Max. distance between toes of fillets of supporting elements for plate	$b'$	=	17			3.4.10.1
	$t$	=	1.5	mm		T3.3(D)
Slenderness	$b/t$	=	11.33333			
		=	3			
Limit 1	$S_1$	=	12.06			
Limit 2	$S_2$	=	49.94			
Factored limit state stress	$\phi F_L$	=	<b>104.50</b>	<b>MPa</b>		
Most adverse compressive limit state stress	$F_a$	=	10.02	MPa		
Most adverse tensile limit state stress	$F_a$	=	104.50	MPa		
Most adverse compressive & Tensile capacity factor	$f_a/F_a$	=	0.01		PASS	
<b>BENDING - IN-PLANE</b>						
<b>3.4.15 Compression in beams, extreme fibre, gross section rectangular tubes, box sections</b>						
Unbraced length for bending	$L_b$	=	1850	mm		

Second moment of area (weak axis)	$I_y$	=	8945.75	mm <sup>4</sup>		
Torsion modulus	J	=	17744.20 6	mm <sup>3</sup>		
Elastic section modulus	Z	=	1141.05	mm <sup>3</sup>		
Slenderness	S	=	335.10			
Limit 1	S <sub>1</sub>	=	21.80			
Limit 2	S <sub>2</sub>	=	3854.05			
Factored limit state stress	$\phi F_L$	=	<b>89.12</b>	<b>MPa</b>		3.4.15(2) ...
<b>3.4.17 Compression in components of beams (component under uniform compression), gross section - flat plates with both edges supported</b>						
	$k_1$	=	0.5			T3.3(D)
	$k_2$	=	2.04			T3.3(D)
Max. distance between toes of fillets of supporting elements for plate	$b'$	=	17	mm		
	t	=	1.5	mm		
Slenderness	$b/t$	=	11.33333 3			
Limit 1	S <sub>1</sub>	=	12.06			
Limit 2	S <sub>2</sub>	=	71.35			
Factored limit state stress	$\phi F_L$	=	<b>104.50</b>	<b>MPa</b>		
Most adverse in-plane bending limit state stress	$F_{bx}$	=	89.12	MPa		
Most adverse in-plane bending capacity factor	$f_{bx}/F_{bx}$	=	0.77		PASS	
<b>BENDING - OUT-OF-PLANE</b>						
<i>NOTE: Limit state stresses, <math>\phi F_L</math> are the same for out-of-plane bending (doubly symmetric section)</i>						
Factored limit state stress	$\phi F_L$	=	<b>89.12</b>	<b>MPa</b>		
Most adverse out-of-plane bending limit state stress	$F_{by}$	=	89.12	MPa		
Most adverse out-of-plane bending capacity factor	$f_{by}/F_{by}$	=	0.08		PASS	
<b>COMBINED ACTIONS</b>						
<b>4.1.1 Combined compression and bending</b>						
						... 4.1.1(2)

	$F_a$	=	10.02	MPa	... 3.4.8
	$F_{ao}$	=	104.50	MPa	... 3.4.10
	$F_{bx}$	=	89.12	MPa	... 3.4.17
	$F_{by}$	=	89.12	MPa	... 3.4.17
	$f_a/F_a$	=	0.014		
	Check:	$f_a/F_a + f_{bx}/F_{bx} + f_{by}/F_{by} \leq 1.0$			... 4.1.1 (3)
	i.e.	0.87	$\leq$	1.0	PASS
<b>SHEAR</b>					
<b>3.4.24 Shear in webs (Major Axis)</b>					
					... 4.1.1(2)
Clear web height	$h$	=	27	mm	
	$t$	=	1.5	mm	
Slenderness	$h/t$	=	18		
Limit 1	$S_1$	=	33.38		
Limit 2	$S_2$	=	59.31		
Factored limit state stress	$\phi F_L$	=	58.90	MPa	
Stress From Shear force	$f_{sx}$	=	$V/A_w$		
			0.94	MPa	
<b>3.4.25 Shear in webs (Minor Axis)</b>					
Clear web height	$b$	=	17	mm	
	$t$	=	1.5	mm	
Slenderness	$b/t$	=	11.33333 3		
Factored limit state stress	$\phi F_L$	=	58.90	MPa	
Stress From Shear force	$f_{sy}$	=	$V/A_w$		
			0.22	MPa	
Most adverseshear capacity factor (Major Axis)	$f_{sx}/F_{sx}$	=	0.02	MPa	
Most adverseshear capacity factor (Minor Axis)	$f_{sy}/F_{sy}$	=	0.00	Mpa	PASS
<b>COMBINED ACTIONS</b>					
<b>4.4 Combined Shear, Compression and bending</b>					
	Check:	$f_a/F_a + f_b/F_b + (f_s/F_s)^2 \leq 1.0$			
	i.e.	0.79	$\leq$	1.0	PASS

## 11.1.7 Centre Pole



Job no. 21-174-2

Date: 17/01/2022

NAME	SYMBOL	VALUE	UNIT	NOTES	REF
<b>48x1.8</b>	<b>Centre Pole</b>				
Alloy and temper	6063-T5				AS1664.1
Tension	$F_{tu}$	= 152	MPa	Ultimate	T3.3(A)
	$F_{ty}$	= 110	MPa	Yield	
Compression	$F_{cy}$	= 110	MPa		
Shear	$F_{su}$	= 90	MPa	Ultimate	
	$F_{sy}$	= 62	MPa	Yield	
Bearing	$F_{bu}$	= 317	MPa	Ultimate	
	$F_{by}$	= 179	MPa	Yield	
Modulus of elasticity	E	= 70000	MPa	Compressive	
	$k_t$	= 1.0			T3.4(B)
	$k_c$	= 1.1			
<b>FEM ANALYSIS RESULTS</b>					
Axial force	P	= 0.516	kN	compression	
	P	= 0	kN	Tension	
In plane moment	$M_x$	= 0	kNm		
Out of plane moment	$M_y$	= 0	kNm		
<b>DESIGN STRESSES</b>					
Gross cross section area	$A_g$	= 261.25485	mm <sup>2</sup>		
In-plane elastic section modulus	$Z_x$	= 2908.7461	mm <sup>3</sup>		
Out-of-plane elastic section mod.	$Z_y$	= 2908.7461	mm <sup>3</sup>		
Stress from axial force	$f_a$	= P/ $A_g$			
		= 1.98	MPa	compression	
		= 0.00	MPa	Tension	
Stress from in-plane bending	$f_{bx}$	= $M_x/Z_x$			
		= 0.00	MPa	compression	

Stress from out-of-plane bending	$f_{by}$	=	$M_y/Z_y$			
		=	<b>0.00</b>	<b>MPa</b>	<i>compression</i>	
<i>Tension</i>						
<b>3.4.3 Tension in rectangular tubes</b>						3.4.3
	$\phi F_L$	=	<b>122.27</b>	<b>MPa</b>		
		OR				
	$\phi F_L$	=	<b>160.21</b>	<b>MPa</b>		
<b>COMPRESSION</b>						
<b>3.4.8 Compression in columns, axial, gross section</b>						
1. General						3.4.8.1
Unsupported length of member	L	=	400	mm		
Effective length factor	k	=	1.00			
Radius of gyration about buckling axis (Y)	$r_y$	=	16.35	mm		
Radius of gyration about buckling axis (X)	$r_x$	=	16.35	mm		
Slenderness ratio	$kLb/r_y$	=	24.47			
Slenderness ratio	$kL/r_x$	=	24.47			
Slenderness parameter	$\lambda$	=	0.309			
	$D_c^*$	=	39.0			
	$S_1^*$	=	0.54			
	$S_2^*$	=	1.25			
	$\phi_{cc}$	=	0.935			
Factored limit state stress	$\phi F_L$	=	<b>91.85</b>	<b>MPa</b>		
2. Sections not subject to torsional or torsional-flexural buckling						3.4.8.2
Largest slenderness ratio for flexural buckling	$kL/r$	=	24.47			
<b>3.4.11 Uniform compression in components of columns, gross section - flat plates</b>						
<i>Uniform compression in components of columns, gross section - curved plates with both edges, walls of round or oval tube</i>						3.4.11
	$k_1$	=	0.35			T3.3(D)
mid-thickness radius of round tubular column or maximum mid-thickness radius	$R_m$	=	23.1			
	t	=	1.8	mm		
Slenderness	$R_m/t$	=	12.833333			
Limit 1	$S_1$	=	1.69			
Limit 2	$S_2$	=	672.46			

Factored limit state stress	$\phi F_L$	=	<b>103.88</b>	<b>MPa</b>		
Most adverse compressive limit state stress	$F_a$	=	91.85	MPa		
Most adverse tensile limit state stress	$F_a$	=	122.27	MPa		
Most adverse compressive & Tensile capacity factor	$f_a/F_a$	=	0.02		PASS	
<b>BENDING - IN-PLANE</b>						
<b>3.4.13</b> <i>Compression in beams, extreme fibre, gross section round or oval tubes</i>						
Unbraced length for bending	$L_b$	=	400	mm		
Second moment of area (weak axis)	$I_y$	=	6.98E+04	mm <sup>4</sup>		
Torsion modulus	$J$	=	1.40E+05	mm <sup>3</sup>		
Elastic section modulus	$Z$	=	2908.7461	mm <sup>3</sup>		
	$R_b/t$	=	12.83			
Limit 1	$S_1$	=	17.65			
Limit 2	$S_2$	=	79.80			
Factored limit state stress	$\phi F_L$	=	<b>122.27</b>	<b>MPa</b>		3.4.13
<b>3.4.18</b> <i>Compression in components of beams - curved plates with both edges supported</i>						
	$k_1$	=	0.5			T3.3(D)
	$k_2$	=	2.04			T3.3(D)
mid-thickness radius of round tubular column or maximum mid-thickness radius	$R_b$	=	23.1	mm		
	$t$	=	1.8	mm		
Slenderness	$R_b/t$	=	12.833333			
Limit 1	$S_1$	=	10.67			
Limit 2	$S_2$	=	79.80			
Factored limit state stress	$\phi F_L$	=	<b>101.17</b>	<b>MPa</b>		
Most adverse in-plane bending limit state stress	$F_{bx}$	=	101.17	MPa		
Most adverse in-plane bending capacity factor	$f_{bx}/F_{bx}$	=	0.00		PASS	
<b>BENDING - OUT-OF-PLANE</b>						

NOTE: Limit state stresses, $\phi F_L$ are the same for out-of-plane bending (doubly symmetric section)					
Factored limit state stress	$\phi F_L$	=	101.17 MPa		
Most adverse out-of-plane bending limit state stress	$F_{by}$	=	101.17 MPa		
Most adverse out-of-plane bending capacity factor	$f_{by}/F_{by}$	=	0.00	PASS	
<b>COMBINED ACTIONS</b>					
<b>4.1.1 Combined compression and bending</b>					4.1.1
	$F_a$	=	91.85 MPa		3.4.11
	$F_{ao}$	=	103.88 MPa		3.4.11
	$F_{bx}$	=	101.17 MPa		3.4.18
	$F_{by}$	=	101.17 MPa		3.4.18
	$f_a/F_a$	=	0.022		
Check:	$f_a/F_a + f_{bx}/F_{bx} + f_{by}/F_{by} \leq 1.0$				4.1.1
i.e.	0.02	≤	1.0	PASS	
<b>SHEAR</b>					
<b>3.4.24 Shear in webs (Major Axis)</b>					3.4.24
	R	=	24 mm		
	t	=	1.8 mm		
Equivalent h/t	h/t	=	29.58		
Limit 1	$S_1$	=	33.38		
Limit 2	$S_2$	=	59.31		
Factored limit state stress	$\phi F_L$	=	58.90 MPa		
Stress From Shear force	$f_{sx}$	=	$V/A_w$		
			0.00 MPa		
<b>3.4.25 Shear in webs (Minor Axis)</b>					3.4.24
Clear web height	R	=	24 mm		
	t	=	1.8 mm		
Equivalent h/t	h/t	=	29.58		
Factored limit state stress	$\phi F_L$	=	58.90 MPa		
Stress From Shear force	$f_{sy}$	=	$V/A_w$		
			0.00 MPa		

Most adverse shear capacity factor (Major Axis)	$f_{sx}/F_{sx}$	=	0.00	MPa		
Most adverse shear capacity factor (Minor Axis)	$f_{sy}/F_{sy}$	=	0.00	Mpa	PASS	
<b>COMBINED ACTIONS</b>						
<b>4.4 Combined Shear, Compression and bending</b>						4.4
Check: $f_a/F_a + f_b/F_b + (f_s/F_s)^2 \leq 1.0$						
i.e. 0.02 ≤ 1.0						PASS

### 11.1.8 Summary Forces

MEMBER(S)	Section	b	d	t	Vx	Vy	P	Mx	My
		mm	mm	mm	kN	kN	kN	kN.m	kN.m
Post	120x85x3	85	120	3	-0	0.048	-0.524	0.8242	-0.2379
Cantilever Beam	60x35x3.5	35	60	3.5	-0.48	0.327	-0.057	-0.3859	0.1841
Brace 1	60x35x3.5	35	60	3.5	0.008	-0.375	-0.117	7.227E-19	0.2362
Brace 2	30x20x1.5	20	30	1.5	-0	0.026	-0.272	0	0.0154
Middle Beam	30x20x1.5	20	30	1.5	0.069	-0.012	0.162	-0.0477	0.0018
Corner Beam	30x20x1.5	20	30	1.5	-0.11	-0.026	0.201	-0.0788	-0.0062

MEMBER(S)	Section	d	t	Vx	Vy	P (Axial)	Mx	My
		mm	mm	kN	kN	kN	kN.m	kN.m
Centre Pole	48x1.8	48	1.8	0	0	-0.516	0	0



# 12 Appendix 'C' – Anchorage Design

AFOS 2.0.3 (12012022) - Extended report

Company: Prime Consulting Engineers Pty. Ltd.  
 Designer: KZ  
 Address: 21/1-7 Jordan St, Gladesville  
 Project: 3.5m SQ Cantilever Umbrella  
 Comments:

E-mail: info@primeengineers.com.au  
 Phone: 02 8964 1818  
 Fax:  
 Date: 1/21/2022  
 Page: 1 / 7

## 1. Input Data

### Selected anchors:

- HLA-Z1 M10  
 Sleeve anchor  
 Zinc plated  
 Design based on AS 5216
- Assessment ETA-02/0030 (SZ)  
 Issued by DIBt, on 9/13/2019
- Effective anchorage depth  $h_{ef} = 80$  mm
- Drilled hole  $\Phi \times h_0 = 15.0 \times 104$  mm



### Base material:

- Cracked concrete, Thickness of base material  $h = 180$  mm  
 Strength class 32MPa,  $f_c = 32.0$  N/mm<sup>2</sup>
- Wide concrete reinforcement  
 Rebar spacing  $a \geq 150$  mm for all  $\Phi$  or  $a \geq 100$  mm for  $\Phi \leq 10$  mm
- No edge and stirrup reinforcement
- Hammer drilled hole

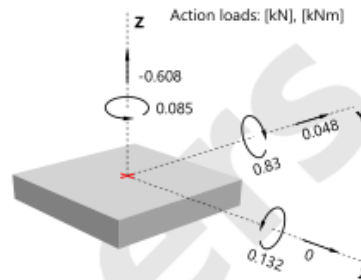

### Action loads:

- Predominantly static and quasi-static design loads

### Installation:

- Base plate lies on the concrete surface directly
- Without gap filling

### Base plate:

- G250,  $E = 200000$  N/mm<sup>2</sup>  
 $f_y = 250$  N/mm<sup>2</sup>,  $\phi_s = 0.741$ ,  $f_{yd} = \phi_s \cdot f_y$
- Assumed: elastic plate
- Current thickness: 12.0 mm  
 $\sigma/f_{yd} = 50.6/185.2 = 27.3\%$
- Circle  
 Diameter: 180 mm

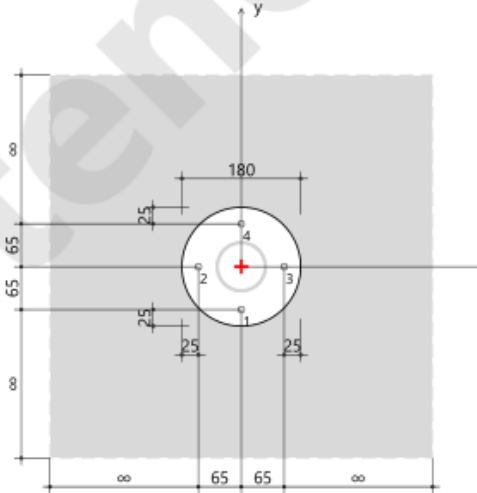

### Profile:

- Circular Hollow Section: 76.1x3.2 CHS  
 $H \times W \times T \times FT$  [mm]: 76 x 76 x 3.2 x 0.0
- Action point [mm]: [0, 0]
- Rotation counterclockwise: 0°
- No profile stiffness

### Coordinates of anchors [mm]:

No.	x	y	Slotted hole	
			L-x	L-y
1	0.0	-65.0		
2	-65.0	0.0		
3	65.0	0.0		
4	0.0	65.0		

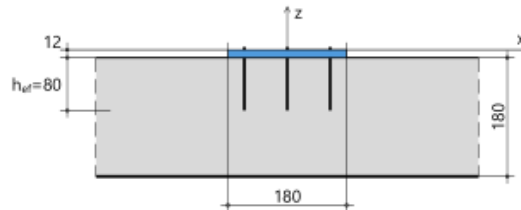

**AFOS 2.0.3** (12012022) - Extended report

Company:	Prime Consulting Engineers Pty. Ltd.	E-mail:	info@primeengineers.com.au
Designer:	KZ	Phone:	02 8964 1818
Address:	21/1-7 Jordan St, Gladesville	Fax:	
Project:	3.5m SQ Cantilever Umbrella	Date:	1/21/2022
Comments:		Page:	2 / 7

**Load cases, design load:** [kN], [kNm]

Active	No.	N <sub>x</sub>	V <sub>x</sub>	V <sub>y</sub>	M <sub>x</sub>	M <sub>y</sub>	M <sub>z</sub>	Utilization	Decisive
⊙	1	-0.608	0.0	0.048	0.085	0.132	0.83	39.6%	
	2	0.251	0.0	0.012	0.02	0.032	-0.62		

**2. Anchor internal forces [kN]**

Tension load of anchors is calculated with elastic base plate.

Assumed: Anchor stiffness factor 0.50 → Anchor spring constant C<sub>G</sub> = 70.8 kN/mm.

Assumed: coefficient for concrete bedding factor b = 15.0 → concrete bedding factor C<sub>c</sub> = b · f<sub>c</sub> = 480.0 N/mm<sup>2</sup>

Anchor No.	Tension N <sub>i</sub>	Shear V <sub>i</sub>	Shear x	Shear y
1	1.026	0.327	0.327	0.012
2	5.328	0.315	0.000	-0.315
3	0.000	0.339	0.000	0.339
4	2.116	0.327	-0.327	0.012

Maximum plate displacement into concrete (x/y=48.9/-10.4): 0.007 [mm]

Maximum concrete compressive stress: 3.31 [N/mm<sup>2</sup>]

Mean concrete compressive stress: 1.23 [N/mm<sup>2</sup>]

Resultant tension force in (x/y=-40.9/8.4): 8.470 [kN]

Resultant compression force in (x/y=53.1/-6.7): 9.078 [kN]

Remark: The edge distance is not to scale.

Displacement and rotation of profile on base plate <sup>\*)</sup>

Displacement δ<sub>z</sub> (+ve out of concrete): 0.031782 [mm]

Rotation θ<sub>x</sub>: 0.000190 [rad]

Rotation θ<sub>y</sub>: 0.001089 [rad]

<sup>\*)</sup> Calculated using the best fit plane

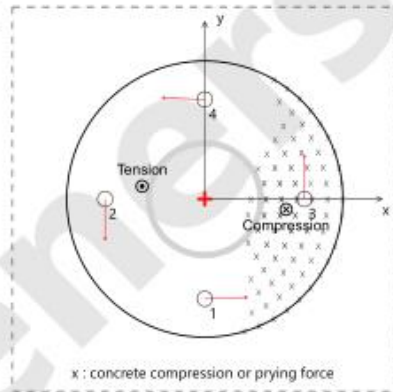

Bending stresses in the base plate

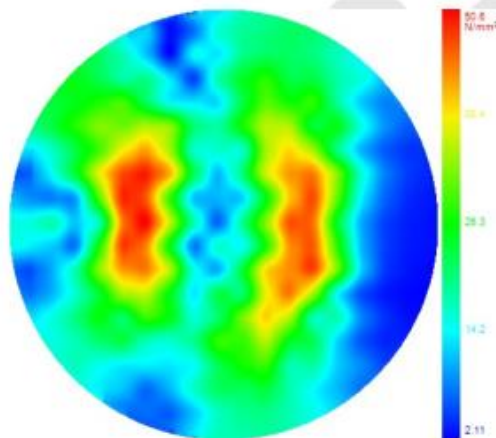

Concrete compression stresses under the base plate

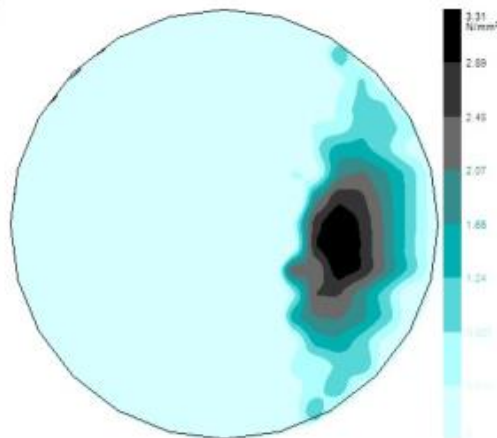

**AFOS 2.0.3 (12012022) - Extended report**

Company: Prime Consulting Engineers Pty. Ltd.  
 Designer: KZ  
 Address: 21/1-7 Jordan St, Gladesville  
 Project: 3.5m SQ Cantilever Umbrella  
 Comments:

E-mail: info@primeengineers.com.au  
 Phone: 02 8964 1818  
 Fax:  
 Date: 1/21/2022  
 Page: 3 / 7

**3. Verification at ultimate limit state based on AS 5216**
**3.1 Tension load**

	Related anchor	Action [kN]	Resistance [kN]	Utilization [%]	Status
Steel failure	2	5.328	30.667	17.4	✓
Pull-out	2	5.328	13.440	<b>39.6</b>	✓
Concrete cone failure	1,2,4	8.470	36.625	23.1	✓
Concrete cone failure e <sup>-1</sup>	-	-	-	-	not applicable
Splitting failure	-	-	-	-	not applicable

<sup>†</sup> additional proof for the fastening with elastic base plate

**Steel failure**

$$N_{Rd,s} = N_{Rk,s} \cdot \phi_{s,N} \quad \beta_{N,s} = N^* / N_{Rd,s}$$

$N_{Rk,s}$ [kN]	$\phi_{s,N}$	$N_{Rd,s}$ [kN]	$N^*$ [kN]	$\beta_{N,s}$
46.0	0.667	30.667	5.328	0.174

**Pull-out**

$$N_{Rd,p} = N_{Rk,p}^0 \cdot \psi_c \cdot \phi_{p,N} \quad \beta_{N,p} = N^* / N_{Rd,p}$$

$N_{Rk,p}^0$ [kN]	$\psi_c$	$\phi_{p,N}$	$N_{Rd,p}$ [kN]	$N^*$ [kN]	$\beta_{N,p}$
16.0	1.26	0.667	13.440	5.328	0.396

**Concrete cone failure**

$$N_{Rk,c} = N_{Rk,c}^0 \cdot \psi_{A,N} \cdot \psi_{s,N} \cdot \psi_{re,N} \cdot \psi_{ec,N} \cdot \psi_{M,N} \quad N_{Rk,c}^0 = k_1 \cdot (f_c)^{0.5} \cdot h_{ef}^{1.5} \text{ [N]} \quad \psi_{A,N} = A_{c,N} / A_{c,N}^0 \quad N_{Rd,c} = N_{Rk,c} \cdot \phi_{c,N}$$

$N_{Rk,c}^0$ [kN]	$A_{c,N}$ [mm <sup>2</sup> ]	$A_{c,N}^0$ [mm <sup>2</sup> ]	$\psi_{A,N}$	$k_1$	$\phi_{c,N}$	$h_{ef}$ [mm]	$s_{cr,N}$ [mm]	$c_{cr,N}$ [mm]	$\psi_{s,N}$	$\psi_{re,N}$	$e_{N,x}$ [mm]	$e_{N,y}$ [mm]	$\psi_{ec,N,x}$	$\psi_{ec,N,y}$	$\psi_{ec,N}$	$\psi_{M,N}$	$N_{Rk,c}$ [kN]	$N_{Rd,c}$ [kN]	$N^*$ [kN]	$\beta_{N,c}$
31.167	104400	57600	1.813	7.7	0.667	80.0	240.0	120.0	1.0	1.0	19.2	8.4	0.862	0.935	0.806	1.207	54.937	36.625	8.470	0.231

**Concrete cone failure for single anchor** (additional proof for the fastening with elastic base plate)

Verification is not required.

**Splitting**

Verification of splitting failure is not necessary, because:

- The smallest edge distance of anchor is  $c \geq 1.2 c_{cr,sp}$ .

**3.2 Shear**

	Related anchor	Action [kN]	Resistance [kN]	Utilization [%]	Status
Steel failure (without l. arm)	3	0.339	38.400	0.9	✓
Pry-out	3	0.339	21.509	<b>1.6</b>	✓
Concrete edge failure	-	-	-	-	not applicable

**Steel failure without lever arm**

$$V_{Rd,s} = V_{Rk,s} \cdot k_7 \cdot \phi_{s,V} \quad \beta_{V,s} = V^* / V_{Rd,s}$$

$V_{Rk,s}$ [kN]	$k_7$	$\phi_{s,V}$	$V_{Rd,s}$ [kN]	$V^*$ [kN]	$\beta_{V,s}$
48.0	1.0	0.8	38.400	0.339	0.009

**AFOS 2.0.3** (12012022) - Extended report

Company: Prime Consulting Engineers Pty. Ltd.	E-mail: info@primeengineers.com.au
Designer: KZ	Phone: 02 8964 1818
Address: 21/1-7 Jordan St, Gladesville	Fax:
Project: 3.5m SQ Cantilever Umbrella	Date: 1/21/2022
Comments:	Page: 4 / 7

**Pry-out failure**

$$N_{Rk,c} = N_{Rk,c}^0 \cdot \psi_{A,N} \cdot \psi_{s,N} \cdot \psi_{re,N} \cdot \psi_{ec,v,cp}$$

$$N_{Rk,c}^0 = k_1 \cdot (f_c)^{0.5} \cdot h_{ef}^{1.5} \text{ [N]}$$

$$\psi_{A,N} = A_{c,N} / A_{c,N}^0$$

$$V_{Rk,cp} = k_s \cdot N_{Rk,c}$$

$$V_{Rd,cp} = V_{Rk,cp} \cdot \phi_{cp,v}$$

$N_{Rk,c}^0$ [kN]	$A_{c,N}$ [mm <sup>2</sup> ]	$A_{c,N}^0$ [mm <sup>2</sup> ]	$\psi_{A,N}$	$\psi_{s,N}$	$\psi_{re,N}$	$h_{ef}$ [mm]	$s_{cr,N}$ [mm]	$c_{cr,N}$ [mm]	$k_1$	$k_s$	$\phi_{cp,v}$
31.167	29813	57600	0.518	1.0	1.0	80.0	240.0	120.0	7.7	2.0	0.667

$e_{v,cp,x}$ [mm]	$e_{v,cp,y}$ [mm]	$\psi_{ec,v,cp,x}$	$\psi_{ec,v,cp,y}$	$\psi_{ec,v,cp}$	$N_{Rk,c}$ [kN]	$V_{Rk,cp}$ [kN]	$V_{Rd,cp}$ [kN]	$V^*$ [kN]	$\beta_{v,cp}$
0.0	0.0	1.0	1.0	1.0	16.132	32.264	21.509	0.339	0.016

Related area for calculation of pry-out failure  $A_{c,N}$  :

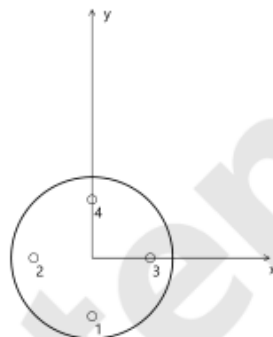

**Concrete edge failure**

Verification for concrete edge failure is not necessary, because there is no concrete edge.

**3.3 Combined tension and shear**

	Anchor	Tension( $\beta_N$ )	Shear( $\beta_V$ )	Condition	Utilization (%)	Status
Steel	2	0.174	0.008	$\beta_N^2 + \beta_V^2 \leq 1.0$	3.0	✓
Concrete	2	0.396	0.015	$\beta_N^{1.5} + \beta_V^{1.5} \leq 1.0$	<b>25.1</b>	✓

**Anchor-related utilization**

A-No.	$\beta_{N,s}$	$\beta_{N,sp}$	$\beta_{N,c}$	$\beta_{N,ec}$	$\beta_{N,sp}$	$\beta_{V,s}$	$\beta_{V,cp}$	$\beta_{V,c}$	$\beta_{N,max,E}$	$\beta_{V,max,E}$	$\beta_{comb,c,E}$	$\beta_{comb,s,E}$
1	0.033	0.076	0.231	0.000	0.000	0.009	0.015	0.000	0.231	0.015	0.113	0.001
2	0.174	0.396	0.231	0.000	0.000	0.008	0.015	0.000	0.396	0.015	0.251	0.030
3	0.000	0.000	0.000	0.000	0.000	0.009	0.016	0.000	0.000	0.016	0.002	0.000
4	0.069	0.157	0.231	0.000	0.000	0.009	0.015	0.000	0.231	0.015	0.113	0.005

$\beta_{N,max,E}$  : Highest utilization of individual anchors under tension loading except steel failure  
 $\beta_{V,max,E}$  : Highest utilization of individual anchors under shear loading except steel failure  
 $\beta_{comb,c,E}$  : Utilization of individual anchors under combined tension and shear loading except steel failure  
 $\beta_{comb,s,E}$  : Utilization of individual anchors under combined tension and shear loading at steel failure

AFOS 2.0.3 (12012022) - Extended report

Company: Prime Consulting Engineers Pty. Ltd.	E-mail: info@primeengineers.com.au
Designer: KZ	Phone: 02 8964 1818
Address: 21/1-7 Jordan St, Gladesville	Fax:
Project: 3.5m SQ Cantilever Umbrella	Date: 1/21/2022
Comments:	Page: 5 / 7

4. Displacement

Tension loading:

$$N_k^h = N^h / 1.4$$

Short-term displacement:  $\delta_{N0}^0 = (N_k^h / N_0) \cdot \delta_{N0}$

Long-term displacement:  $\delta_{N\infty}^{\infty} = (N_k^h / N_0) \cdot \delta_{N\infty}$

Shear loading:

$$V_k^h = V^h / 1.4$$

Short-term displacement:  $\delta_{V0}^0 = (V_k^h / V_0) \cdot \delta_{V0}$

Long-term displacement:  $\delta_{V\infty}^{\infty} = (V_k^h / V_0) \cdot \delta_{V\infty}$

$N^h$ [kN]	$N_0$ [kN]	$\delta_{N0}$ [mm]	$\delta_{N\infty}$ [mm]	$\delta_{N0}^0$ [mm]	$\delta_{N\infty}^{\infty}$ [mm]	$V^h$ [kN]	$V_0$ [kN]	$\delta_{V0}$ [mm]	$\delta_{V\infty}$ [mm]	$\delta_{V0}^0$ [mm]	$\delta_{V\infty}^{\infty}$ [mm]
5.328	7.6	0.5	1.3	<b>0.250</b>	<b>0.651</b>	0.339	27.5	3.6	5.4	<b>0.032</b>	<b>0.048</b>

5. Remarks

- Capacity verifications of Section 3 are in accordance with AS 5216. For more complex cases which are outside of AS 5216, the same principles of AS 5216 are still used.
- For connections with a flexurally rigid base plate, it is assumed that the base plate is sufficiently rigid. However, the current anchor design methods (ETAG, Eurocode, AS 5216, ACI 318, CSA A23.3) do not provide any usable guidance to check for rigidity. In the realistically elastic (flexible) base plate, the tension load distribution between anchors may be different to that in the assumed rigid base plate. The plate prying effects could further increase anchor tension loading. To verify the sufficient base plate bending rigidity, the stiffness condition according to the publication "Required Thickness of Flexurally Rigid Base plate for Anchor Fastenings" (fib Symposium 2017 Maastricht) is used in this software.
- For connections with an elastic base plate, the anchor tension forces are calculated with the finite element method with consideration of deformations of base plate, anchors and concrete. Background for design with elastic base plates is described in the paper "Design of Anchor Fastenings with Elastic Base Plates Subjected to Tension and Bending". This paper was published in "Stahlbau 88 (2019), Heft 8" and "5. Jahrestagung des Deutschen Ausschusses für Stahlbeton - DAfStb 2017". Anchor shear forces are calculated with the assumption of a rigid base plate. Attention should be paid to a narrow base plate with a width to length ratio of less than 1/3.
- Verification for the ultimate limit state and the calculated displacement under service working load are valid only if the anchors are installed properly according to ETA.
- For design in cracked concrete, anchor design standards/codes assume that the crack width is limited to  $\leq 0.3\text{mm}$  by reinforcement. Splitting failure in cracked concrete is prevented by this reinforcing. The user needs to verify that this reinforcing is present in cracked concrete. Generally, concrete structures design standards/codes (e.g. AS 3600) meet this crack width requirement for most structures. Particular caution must be taken at close edge distances where the location of reinforcing is not clearly known.
- Verification of strength of concrete elements to loads applied by fasteners is to be done in accordance with AS 5216.
- All information in this report is for use of Allfasteners products only. It is the responsibility of the user to ensure that the latest version of the software is used, and in accordance with AFOS licensing agreement. This software serves only as an aid to interpret the standards and approvals without any guarantee to the absence of errors. The results of the software should be checked by a suitably qualified person for correctness and relevance of the results for the application.

The load-bearing capacity of the anchorage is: **verified !**

**AFOS 2.0.3** (12012022) - Extended report

Company: Prime Consulting Engineers Pty. Ltd.  
Designer: KZ  
Address: 21/1-7 Jordan St, Gladesville  
Project: 3.5m SQ Cantilever Umbrella  
Comments:

E-mail: info@primeengineers.com.au  
Phone: 02 8964 1818  
Fax:  
Date: 1/21/2022  
Page: 6 / 7

**Anchorage figure in 3D:**

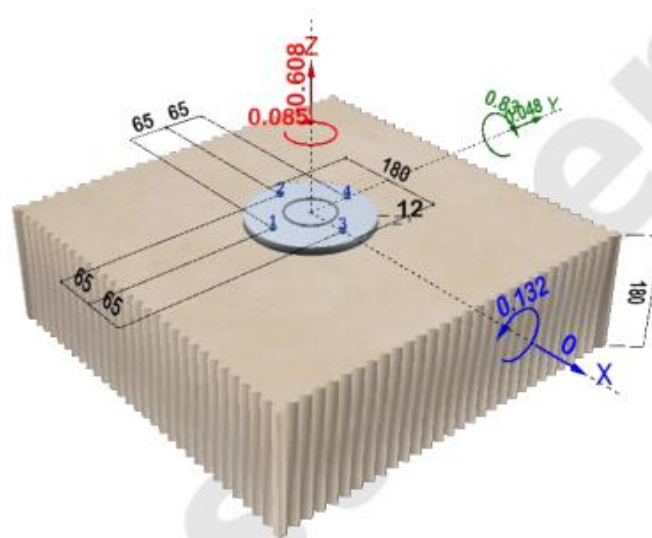

**AFOS 2.0.3** (12012022) - Extended report

Company: Prime Consulting Engineers Pty. Ltd.  
 Designer: KZ  
 Address: 21/1-7 Jordan St, Gladesville  
 Project: 3.5m SQ Cantilever Umbrella  
 Comments:

E-mail: info@primeengineers.com.au  
 Phone: 02 8964 1818  
 Fax:  
 Date: 1/21/2022  
 Page: 7 / 7

**Anchor:** **HLA-Z1 M10**  
 Drilled hole:  $d_0 \times h_0 = 15 \times 104 \text{ mm}$   
 Embedment depth:  $h_{nom} = -$   
 Effective anchorage depth:  $h_{ef} = 80 \text{ mm}$   
 Installation torque:  $T_{inst} = 50 \text{ Nm}$



**Base plate:** **G250**  
 Thickness:  $t = 12 \text{ mm}$   
 Clearance hole:  $d_f = 17 \text{ mm}$

